

Submersible Pump in Discharge Tube

Amacan K

Amacan K 700 - 324
Amacan K 700/800 - 330
Amacan K 700 - 371
Amacan K 800 - 370
Amacan K 800 - 400
Amacan K 800 - 401

Installation/Operating Manual

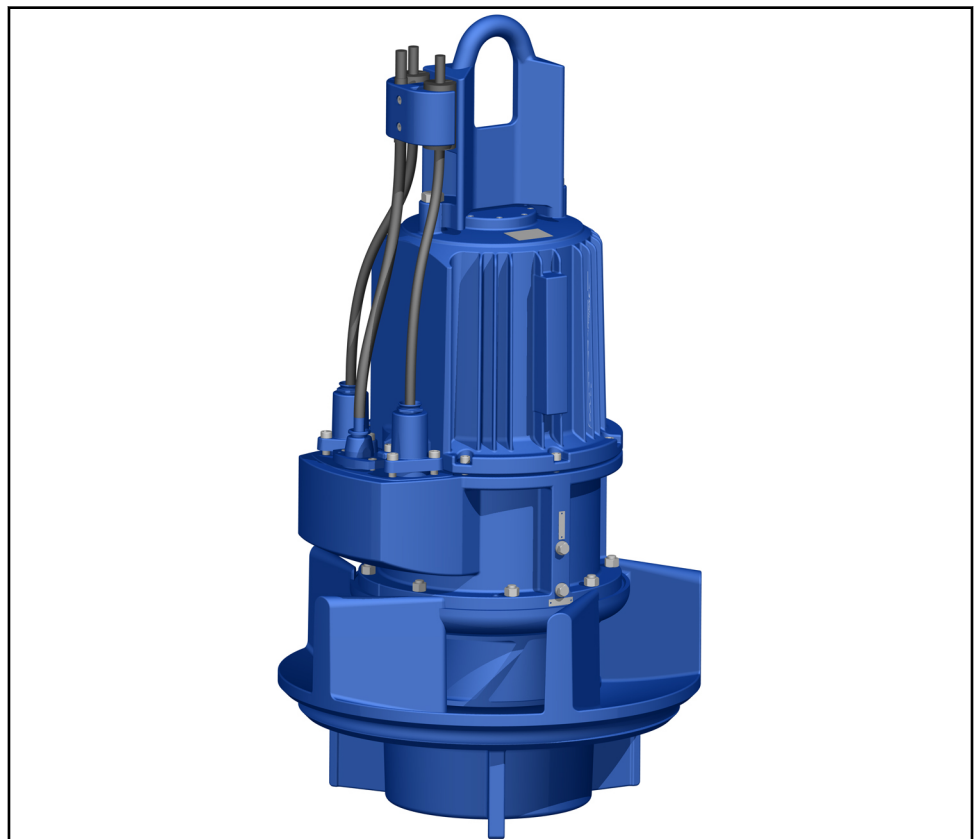

Mat. No.: 01117643

Legal information/Copyright

Installation/Operating Manual Amacan K

Original operating manual

All rights reserved. The contents provided herein must neither be distributed, copied, reproduced, edited or processed for any other purpose, nor otherwise transmitted, published or made available to a third party without the manufacturer's express written consent.

Subject to technical modification without prior notice.

© KSB Aktiengesellschaft, Frankenthal 21.06.2016

Contents

1	General	6
1.1	Principles	6
1.2	Installation of partly completed machinery	6
1.3	Target group	6
1.4	Other applicable documents	6
1.5	Symbols	6
2	Safety	7
2.1	Key to safety symbols/markings	7
2.2	General	7
2.3	Intended use	7
2.4	Personnel qualification and training	8
2.5	Consequences and risks caused by non-compliance with this manual	8
2.6	Safety awareness	8
2.7	Safety information for the operator/user	8
2.8	Safety information for maintenance, inspection and installation	9
2.9	Unauthorised modes of operation	9
2.10	Explosion protection	9
3	Transport/Temporary Storage/Disposal	11
3.1	Checking the condition upon delivery	11
3.2	Transport	11
3.3	Storage/preservation	14
3.4	Return to supplier	15
3.5	Disposal	15
4	Description of the Pump (Set)	16
4.1	General description	16
4.2	Designation	16
4.3	Name plate	16
4.4	Design details	17
4.5	Installation types	17
4.6	Configuration and function	18
4.7	Scope of supply	19
4.8	Dimensions and weights	19
5	Installation at Site	20
5.1	Safety regulations	20
5.2	Checks to be carried out prior to installation	20
5.3	Lowering the pump set into the discharge tube	23
5.4	Electrical system	31
6	Commissioning/Start-up/Shutdown	38

6.1	Commissioning/start-up	38
6.2	Operating limits	39
6.3	Shutdown/storage/preservation	41
6.4	Returning to service	42
7	Servicing/Maintenance	43
7.1	Safety regulations	43
7.2	Maintenance/inspection	44
7.3	Removing the pump set	46
7.4	Lubrication and lubricant change	48
7.5	Dismantling the pump set	51
7.6	Reassembling the pump set	55
7.7	Checking the connection of motor/power supply	59
7.8	Tightening torques	59
7.9	Spare parts stock	60
8	Trouble-shooting	61
9	Related Documents	62
9.1	General assembly drawing	62
9.2	Sectional drawings of the mechanical seal	67
9.3	Cable bundle	68
9.4	Wiring diagrams	70
9.5	Flamepaths on explosion-proof motors	73
9.6	Dimensions	75
9.7	General arrangement drawings	77
10	EU Declaration of Conformity	85
11	Certificate of Decontamination	86

Glossary

Back pull-out unit

Pump without pump casing; partly completed machinery

Certificate of decontamination

A certificate of decontamination is enclosed by the customer when returning the product to the manufacturer to certify that the product

has been properly drained to eliminate any environmental and health hazards arising from components in contact with the fluid handled.

Close-coupled design

Motor directly fitted to the pump via a flange or a drive lantern

Submersible pump in discharge tube

A submersible motor pump which is completely submerged and suspended in a discharge tube

1 General

1.1 Principles

This manual is supplied as an integral part of the type series and variants indicated on the front cover. It describes the proper and safe use of this equipment in all phases of operation.

The name plate indicates the type series and size, the main operating data, the order number and the order item number. The order number and order item number uniquely identify the pump (set) and serve as identification for all further business processes.

In the event of damage, contact your nearest KSB service centre immediately to maintain the right to claim under warranty.

1.2 Installation of partly completed machinery

To install partly completed machinery supplied by KSB refer to the sub-sections under Servicing/Maintenance.

1.3 Target group

This operating manual is aimed at the target group of trained and qualified specialist technical personnel. (⇒ Section 2.4 Page 8)

1.4 Other applicable documents

Table 1: Overview of other applicable documents

Document	Contents
Data sheet	Description of the technical data of the pump (set)
Hydraulic characteristic curve	Characteristic curves showing head, NPSH required, efficiency and power input
General assembly drawing ¹⁾	Sectional drawing of the pump set
Sub-supplier product literature ¹⁾	Operating manuals and other product literature describing accessories and integrated machinery components
Spare parts lists ¹⁾	Description of spare parts

For accessories and/or integrated machinery components observe the relevant manufacturer's product literature.

1.5 Symbols

Table 2: Symbols used in this manual

Symbol	Description
✓	Conditions which need to be fulfilled before proceeding with the step-by-step instructions
▷	Safety instructions
⇨	Result of an action
⇄	Cross-references
1.	Step-by-step instructions
2.	Step-by-step instructions
	Note Recommendations and important information on how to handle the product

¹⁾ If agreed to be included in the scope of supply







2 Safety



All the information contained in this section refers to hazardous situations.

2.1 Key to safety symbols/markings

Table 3: Definition of safety symbols/markings

Symbol	Description
 DANGER	DANGER This signal word indicates a high-risk hazard which, if not avoided, will result in death or serious injury.
 WARNING	WARNING This signal word indicates a medium-risk hazard which, if not avoided, could result in death or serious injury.
 CAUTION	CAUTION This signal word indicates a hazard which, if not avoided, could result in damage to the machine and its functions.
	Explosion protection This symbol identifies information about avoiding explosions in potentially explosive atmospheres in accordance with EC Directive 2014/34/EU (ATEX).
	General hazard In conjunction with one of the signal words this symbol indicates a hazard which will or could result in death or serious injury.
	Electrical hazard In conjunction with one of the signal words this symbol indicates a hazard involving electrical voltage and identifies information about protection against electrical voltage.
	Machine damage In conjunction with the signal word CAUTION this symbol indicates a hazard for the machine and its functions.

2.2 General

This manual contains general installation, operating and maintenance instructions that must be observed to ensure safe pump operation and prevent personal injury and damage to property.

The safety information in all sections of this manual must be complied with.

This manual must be read and completely understood by the specialist personnel/operators responsible prior to installation and commissioning.

The contents of this manual must be available to the specialist personnel at the site at all times.

Information attached directly to the pump must always be complied with and be kept in a perfectly legible condition at all times. This applies to, for example:

- Arrow indicating the direction of rotation
- Markings for connections
- Name plate

The operator is responsible for ensuring compliance with all local regulations not taken into account in this manual.

2.3 Intended use

- The pump (set) must only be operated within the operating limits described in the other applicable documents.
- Only operate pumps/pump sets which are in perfect technical condition.
- Do not operate the pump (set) in partially assembled condition.
- Only use the pump to handle the fluids described in the data sheet or product literature of the pump model or variant.

- Never operate the pump without the fluid to be handled.
- Observe the limits for continuous operation specified in the data sheet or product literature (Q_{\min} and Q_{\max}) (to prevent damage such as shaft fracture, bearing failure, mechanical seal damage, etc).
- Observe the maximum flow rates indicated in the data sheet or product literature (to prevent overheating, mechanical seal damage, cavitation damage, bearing damage, etc).
- Consult the manufacturer about any use or mode of operation not described in the data sheet or product literature.

Prevention of foreseeable misuse

- Observe the minimum flow velocities required to fully open the swing check valves to prevent the reduction of pressure and risk of clogging. (Contact the manufacturer for the required minimum flow velocities/loss coefficients.)
- Never exceed the permissible operating limits specified in the data sheet or product literature regarding pressure, temperature, etc.
- Observe all safety information and instructions in this manual.

2.4 Personnel qualification and training

All personnel involved must be fully qualified to transport, install, operate, maintain and inspect the machinery this manual refers to.

The responsibilities, competence and supervision of all personnel involved in transport, installation, operation, maintenance and inspection must be clearly defined by the operator.

Deficits in knowledge must be rectified by means of training and instruction provided by sufficiently trained specialist personnel. If required, the operator can commission the manufacturer/supplier to train the personnel.

Training on the pump (set) must always be supervised by technical specialist personnel.

2.5 Consequences and risks caused by non-compliance with this manual

- Non-compliance with this operating manual will lead to forfeiture of warranty cover and of any and all rights to claims for damages.
- Non-compliance can, for example, have the following consequences:
 - Hazards to persons due to electrical, thermal, mechanical and chemical effects and explosions
 - Failure of important product functions
 - Failure of prescribed maintenance and servicing practices
 - Hazard to the environment due to leakage of hazardous substances

2.6 Safety awareness

In addition to the safety information contained in this manual and the intended use, the following safety regulations shall be complied with:

- Accident prevention, health and safety regulations
- Explosion protection regulations
- Safety regulations for handling hazardous substances
- Applicable standards, directives and laws

2.7 Safety information for the operator/user

- The operator shall fit contact guards for hot, cold and moving parts and check that the guards function properly.
- Do not remove any contact guards during operation.

- Provide the personnel with protective equipment and make sure it is used.
- Contain leakages (e.g. at the shaft seal) of hazardous fluids handled (e.g. explosive, toxic, hot) so as to avoid any danger to persons and the environment. Adhere to all relevant laws.
- Eliminate all electrical hazards. (In this respect refer to the applicable national safety regulations and/or regulations issued by the local energy supply companies.)
- If shutting down the pump does not increase potential risk, fit an emergency-stop control device in the immediate vicinity of the pump (set) during pump set installation.

2.8 Safety information for maintenance, inspection and installation

- Modifications or alterations of the pump are only permitted with the manufacturer's prior consent.
- Use only original spare parts or parts authorised by the manufacturer. The use of other parts can invalidate any liability of the manufacturer for resulting damage.
- The operator ensures that maintenance, inspection and installation is performed by authorised, qualified specialist personnel who are thoroughly familiar with the manual.
- Only carry out work on the pump (set) during standstill of the pump.
- The pump casing must have cooled down to ambient temperature.
- Pump pressure must have been released and the pump must have been drained.
- When taking the pump set out of service always adhere to the procedure described in the manual. (⇒ Section 6.3 Page 41)
- Decontaminate pumps which handle fluids posing a health hazard.
- As soon as the work has been completed, re-install and/or re-activate any safety-relevant and protective devices. Before returning the product to service, observe all instructions on commissioning. (⇒ Section 6.1 Page 38)

2.9 Unauthorised modes of operation

Never operate the pump (set) outside the limits stated in the data sheet and in this manual.

The warranty relating to the operating reliability and safety of the supplied pump (set) is only valid if the equipment is used in accordance with its intended use.

2.10 Explosion protection



Always observe the information on explosion protection given in this section when operating an explosion-proof pump set.

Sections of the manual marked by the Ex symbol apply to explosion-proof pump sets also when temporarily operated outside of potentially explosive atmospheres. Only pumps/pump sets marked as explosion-proof **and** identified as such in the data sheet may be used in potentially explosive atmospheres.

Special conditions apply to the operation of an explosion-proof pump set to EC Directive 2014/34/EU (ATEX).

Especially adhere to the sections in this manual marked with the Ex symbol.

The explosion-proof status of the pump set is only assured if the pump set is used in accordance with its intended use.

Never operate the pump set outside the limits stated in the data sheet and on the name plate.

Prevent impermissible modes of operation at all times.

2.10.1 Repair

Special regulations apply to repair work on explosion-proof pumps. Modifications or alterations of the pump set can affect explosion protection and are only permitted after consultation with the manufacturer.

Repair work at the flameproof joints must only be performed in accordance with the manufacturer's instructions. Repair to the values in tables 1 and 2 of EN 60079-1 is not permitted.

3 Transport/Temporary Storage/Disposal

3.1 Checking the condition upon delivery

1. On transfer of goods, check each packaging unit for damage.
2. In the event of in-transit damage, assess the exact damage, document it and notify KSB or the supplying dealer (as applicable) and the insurer about the damage in writing immediately.

3.2 Transport

	⚠ DANGER
	<p>Improper transport Danger to life from falling parts! Damage to the pump set!</p> <ul style="list-style-type: none"> ▷ Use the attachment point provided (pump handle) for attaching lifting accessories. ▷ Never suspend the pump set by its power cable. ▷ Use the lifting chain/rope included in the scope of supply exclusively for lowering/lifting the pump set into/out of the pump sump. ▷ Securely attach the lifting chain/rope to the pump and crane. ▷ Use tested, marked and approved lifting accessories only. ▷ Observe any regional transport regulations. ▷ Observe the product literature supplied by the lifting accessory manufacturer. ▷ The load-carrying capacity of the lifting accessory must be higher than the weight indicated on the name plate of the pump set to be lifted. Take into account any additional system components to be lifted.

3.2.1 Transporting the pump set to the place of installation

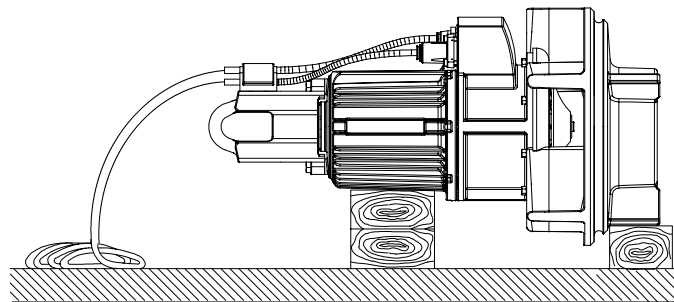







Fig. 1: Transport the pump set in its original packaging

- The pump set is supplied in a horizontal position on a suitable transport support.
- Use suitable lifting equipment to transport the pump set in its original packaging to its place of installation.
 Observe the marked centres of gravity and/or attachment points on the transport boxes!
For the weight refer to the name plate or data sheet.

3.2.2 Placing the pump set in a vertical or horizontal position

	⚠ WARNING
	<p>Pump set tipping over Risk of squashing hands and feet!</p> <ul style="list-style-type: none"> ▷ Suspend or support the pump set.

	<p>⚠ WARNING</p> <p>Placing the pump set down on unsecured and uneven surfaces Personal injury and damage to property!</p> <ul style="list-style-type: none"> ▶ Always set down the pump set on a solid and level surface with the pump set in a vertical position and the motor on top. ▶ Only place the pump set on a surface of sufficient load-carrying capacity. ▶ Use appropriate means to secure the pump set against overturning or tipping over. ▶ Refer to the weights given in the data sheet/on the name plate.
	<p>⚠ WARNING</p> <p>Improper handling of the power cable when placing the pump set in a vertical position or transporting it Personal injury and damage to property!</p> <ul style="list-style-type: none"> ▶ Secure power cables against falling down.
	<p>⚠ WARNING</p> <p>Improper handling when placing the pump set in a vertical/horizontal position Personal injury and damage to property!</p> <ul style="list-style-type: none"> ▶ Depending on the size of the pump (set) use either one or two pieces of lifting equipment. ▶ Use appropriate means to secure the pump set against overturning, tipping over or rolling off. ▶ Maintain adequate safety distance during lifting operations (load may swing when being lifted). ▶ Use additional supports for the transport holder to secure the pump set against overturning.
	<p>⚠ WARNING</p> <p>Improper lifting/moving of heavy assemblies or components Personal injury and damage to property!</p> <ul style="list-style-type: none"> ▶ Use suitable transport devices, lifting equipment and lifting tackle to move heavy assemblies or components.
	<p>CAUTION</p> <p>Improper storage Damage to the power cables!</p> <ul style="list-style-type: none"> ▶ Support the power cables at the cable entry to prevent permanent deformation. ▶ Only remove the protective caps from the power cables at the time of installation.

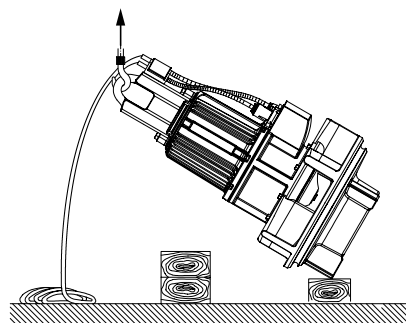





Fig. 2: Placing the pump set in an upright position

- ✓ Suitable lifting equipment has been selected.
- 1. Attach the eye hook to the hoop of the pump set.
- 2. Lift the pump set with the lifting equipment (e.g. crane).
 - ⇒ Guiding the pump set over the inlet of the pump casing is only permissible on a wooden base!
 - ⇒ Protect the power cable against kinking!
- 3. Place the pump set on a level, clean surface and protect it against overturning or tipping over.

3.2.3 Transporting the pump set

	<p>⚠ WARNING</p> <p>Incorrect installation/placing down Personal injury and damage to property!</p> <ul style="list-style-type: none"> ▷ Position the pump set vertically with the motor on top. ▷ Use appropriate means to secure the pump set against overturning and tipping over. ▷ Refer to the weights given in the data sheet/on the name plate.
	<p>⚠ WARNING</p> <p>Improper handling of the power cable when placing the pump set in a vertical position or transporting it Personal injury and damage to property!</p> <ul style="list-style-type: none"> ▷ Secure power cables against falling down.
	<p>⚠ WARNING</p> <p>Improper lifting/moving of heavy assemblies or components Personal injury and damage to property!</p> <ul style="list-style-type: none"> ▷ Use suitable transport devices, lifting equipment and lifting tackle to move heavy assemblies or components.
	<p>⚠ WARNING</p> <p>Improper handling when placing the pump set in a vertical/horizontal position Personal injury and damage to property!</p> <ul style="list-style-type: none"> ▷ Depending on the size of the pump (set) use either one or two pieces of lifting equipment. ▷ Use appropriate means to secure the pump set against overturning, tipping over or rolling off. ▷ Maintain adequate safety distance during lifting operations (load may swing when being lifted). ▷ Use additional supports for the transport holder to secure the pump set against overturning.

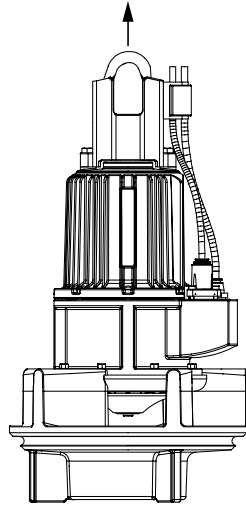

Fig. 3: Transporting the pump set in a vertical position
Use suitable lifting equipment to transport the pump set in the illustrated position.

3.3 Storage/preservation

If commissioning is to take place some time after delivery, we recommend that the following measures be taken:

Store the pump set as follows:

- In its original packaging: in a horizontal position
- Without packaging: in a vertical position with the motor on top

	<p>⚠ WARNING</p>
	<p>Pump set tipping over Risk of squashing hands and feet!</p> <ul style="list-style-type: none"> ▸ Suspend or support the pump set.
	<p>CAUTION</p>
	<p>Improper storage Damage to the power cables!</p> <ul style="list-style-type: none"> ▸ Support the power cables at the cable entry to prevent permanent deformation. ▸ Only remove the protective caps from the power cables at the time of installation.
	<p>CAUTION</p>
	<p>Damage during storage by humidity, dirt, or vermin Corrosion/contamination of the pump (set)!</p> <ul style="list-style-type: none"> ▸ For outdoor storage cover the packed or unpacked pump (set) and accessories with waterproof material.
	<p>CAUTION</p>
	<p>Wet, contaminated or damaged openings and connections Leakage or damage to the pump!</p> <ul style="list-style-type: none"> ▸ Clean and cover pump openings and connections as required prior to putting the pump into storage.

Table 4: Ambient conditions for storage

Ambient condition	Value
Relative humidity	5 % to 85 % (non-condensing)
Ambient temperature	-20 °C to +70 °C

- Store the pump set under dry and vibration-free conditions, if possible in its original packaging.
1. Rotate the impeller by hand once every three months.
 2. Spray-coat the inside wall of the pump casing, and in particular the impeller clearance areas, with a preservative.

	NOTE
	Observe the manufacturer's instructions for application/removal of the preservative.

3.4 Return to supplier

1. Drain the pump as per operating instructions. (⇒ Section 7.3.2 Page 47)
2. Always flush and clean the pump, particularly if it has been used for handling noxious, explosive, hot or other hazardous fluids.
3. If the pump set has handled fluids whose residues could lead to corrosion damage in the presence of atmospheric humidity or could ignite upon contact with oxygen, the pump set must also be neutralised, and anhydrous inert gas must be blown through the pump to ensure drying.
4. Always complete and enclose a certificate of decontamination when returning the pump (set).
Always indicate any safety and decontamination measures taken. (⇒ Section 11 Page 86)

	NOTE
	If required, a blank certificate of decontamination can be downloaded from the KSB web site at: www.ksb.com/certificate_of_decontamination

3.5 Disposal

	⚠ WARNING
	<p>Fluids, consumables and supplies which are hot and/or pose a health hazard Hazard to persons and the environment!</p> <ul style="list-style-type: none"> ▷ Collect and properly dispose of flushing fluid and any residues of the fluid handled. ▷ Wear safety clothing and a protective mask, if required. ▷ Observe all legal regulations on the disposal of fluids posing a health hazard.

1. Dismantle the pump (set).
Collect greases and other lubricants during dismantling.
2. Separate and sort the pump materials, e.g. by:
 - Metals
 - Plastics
 - Electronic waste
 - Greases and other lubricants
3. Dispose of materials in accordance with local regulations or in another controlled manner.

4 Description of the Pump (Set)

4.1 General description

- Submersible pump in discharge tube

Pump set for handling river and stormwater, pre-screened domestic and industrial waste water as well as activated sludge

4.2 Designation

Example: Amacan K 700-330 / 20 6 U G

Table 5: Key to the designation

Code	Description
Amacan	Type series
K	Impeller type
	K Channel impeller
700	Nominal diameter of the discharge tube [mm]
330	Nominal impeller diameter [mm]
20	Motor size
6	Number of motor poles
	4 4 poles
	6 6 poles
	8 8 poles
U	Motor version
	U Standard design
	X Explosion protection to ATEX
G	Material variant
	G Impeller made of grey cast iron, standard variant
G1	Like G, with impeller made of duplex stainless steel

4.3 Name plate

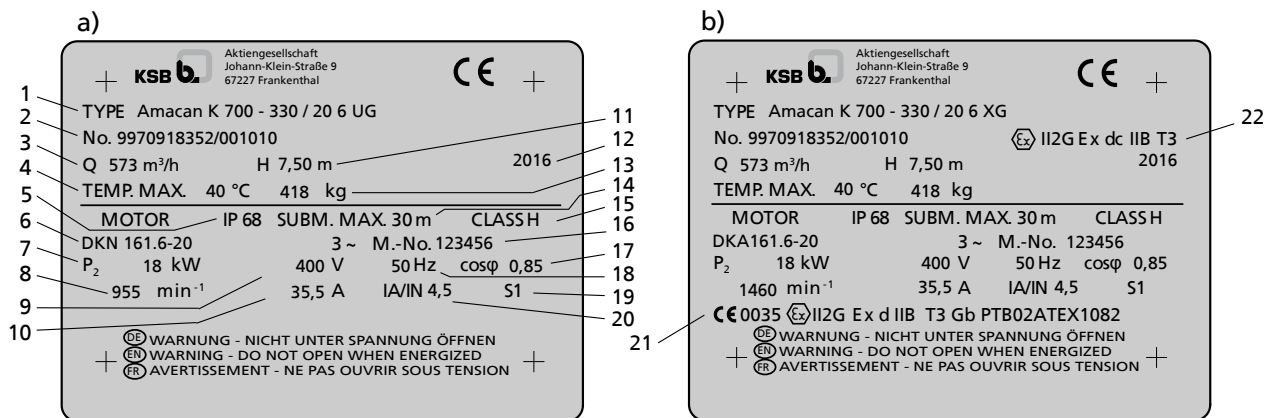

Fig. 4: Name plate (example) a) Standard pump set b) Explosion-proof pump set

1	Designation	2	KSB order number
3	Flow rate	4	Maximum fluid temperature and ambient temperature
5	Enclosure	6	Motor type
7	Rated power	8	Rated speed
9	Rated voltage	10	Rated current
11	Head	12	Year of construction
13	Total weight	14	Maximum submergence
15	Thermal class of winding insulation	16	Motor number
17	Power factor at design point	18	Rated frequency

19	Mode of operation	20	Starting current ratio
21	ATEX marking for the submersible motor	22	ATEX marking for the pump set

4.4 Design details

Design

- Fully floodable submersible pump in discharge tube (submersible motor pump)
- Not self-priming
- Close-coupled design
- Single-stage
- Vertical installation

Impeller type

- Closed channel impeller

Shaft seal

- Two bi-directional mechanical seals in tandem arrangement, with liquid reservoir

Bearings

- Grease-lubricated bearings sealed for life
- Maintenance-free

Drive

- Three-phase asynchronous squirrel-cage motor
- Motors integrated in explosion-proof pump sets are supplied in Ex d IIB type of protection.
- Enclosure: IP68 to EN 60529/IEC529

4.5 Installation types

Table 6: Installation types

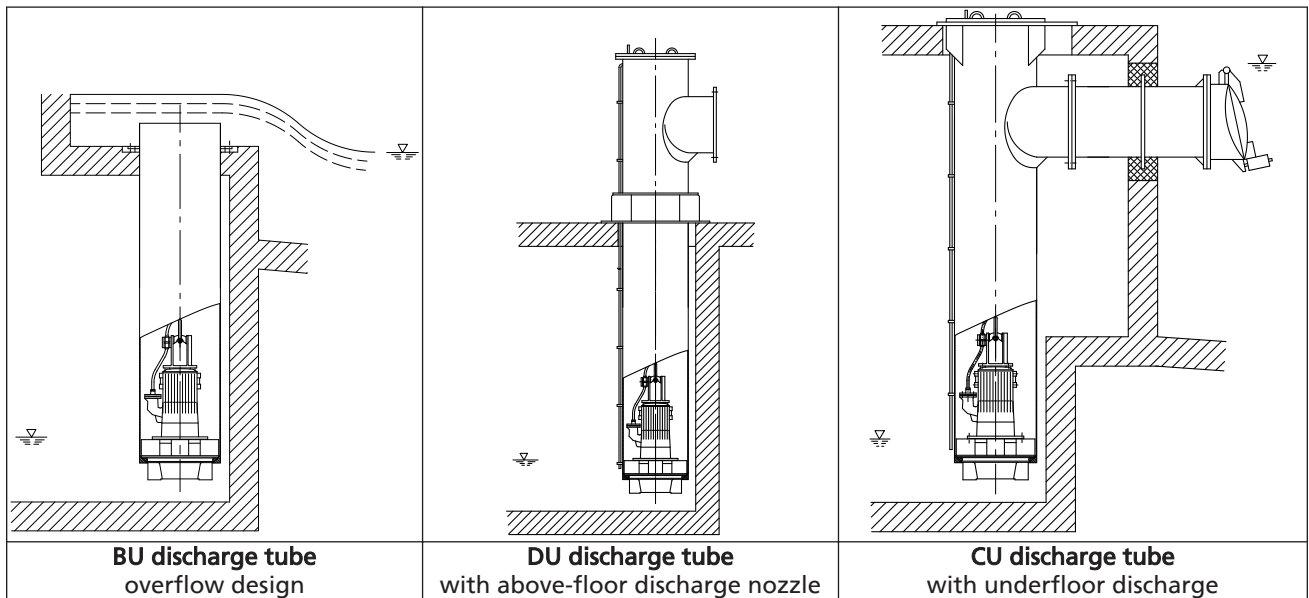

4.6 Configuration and function

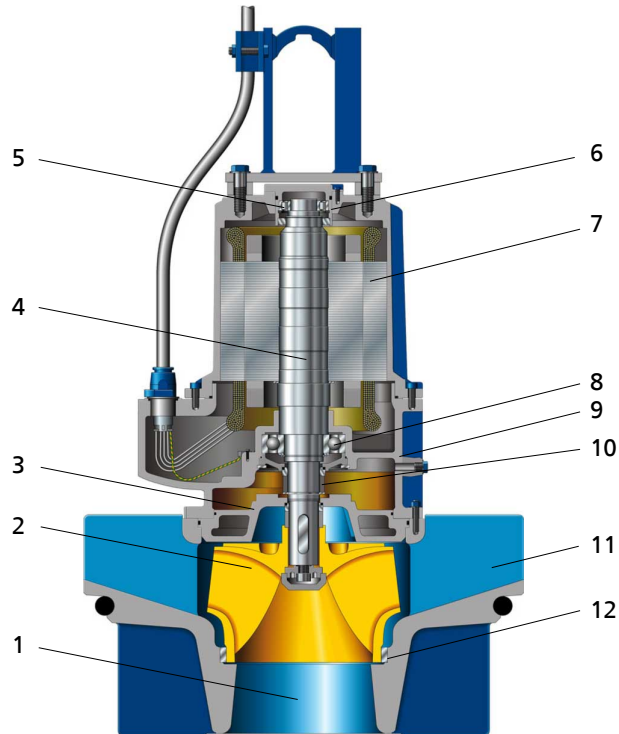

Fig. 5: Amacan with closed channel impeller

1	Inlet of the pump casing	2	Impeller
3	Discharge cover	4	Shaft
5	Drive-end bearing	6	Drive-end bearing bracket or bearing sleeve
7	Electric motor	8	Impeller-end bearing
9	Impeller-end bearing bracket	10	Shaft seal
11	Pump casing	12	Casing wear ring

Design The pump is designed with an axial fluid inlet and a radial fluid outlet. The hydraulic system sits on the extended motor shaft. The shaft runs in common bearings.

Function The fluid enters the pump axially via the inlet of the pump casing (1) and is accelerated outward in a radial flow by the rotating impeller (2). The required energy is transmitted from the electric motor (7) to the impeller (2) via the shaft (4). In the pump casing (11) the kinetic energy of the fluid is converted into pressure energy. The rotational movement diverts the fluid flow in axial direction. The casing wear ring (12) prevents any fluid from flowing back from the casing into the inlet of the pump casing. At the rear side of the impeller, the shaft enters the casing via the discharge cover (3). The shaft passage through the discharge cover is sealed towards the fluid by a shaft seal (10). The shaft runs in rolling element bearings (5 and 8), which are supported by either an impeller-end and a drive-end bearing bracket (9 and 6) or by an impeller-end bearing bracket (9) and a bearing sleeve (6).

Sealing The pump is sealed by two bi-directional mechanical seals in tandem arrangement. A lubricant reservoir in-between the seals ensures cooling and lubrication of the mechanical seals.

Monitoring equipment The pump sets are equipped with various sensors.

Standard

- Temperature monitoring of the motor
- Leakage sensors in the motor

Option

- Temperature monitoring at the lower bearing

4.7 Scope of supply

Depending on the model, the following items are included in the scope of supply:

- Pump set complete with connection cables
- O-ring
- Back-up name plate

Optional accessories:

- Support rope
- Accessories for installing the cable guide:
 - Special pipe part
 - Turnbuckle
 - Support
 - Shackle
 - Hose clips
- Cable support sleeves
- Discharge tube



NOTE



A separate name plate is included in KSB's scope of supply.
This name plate must be attached in a clearly visible position outside the place of installation, e.g. at the control panel, pipeline or mounting bracket.

4.8 Dimensions and weights

For dimensions and weights refer to the name plate or data sheet of the pump set.

5 Installation at Site

5.1 Safety regulations

	<p>⚠ DANGER</p> <p>Improper installation in potentially explosive atmospheres Explosion hazard! Damage to the pump set!</p> <ul style="list-style-type: none"> ▸ Comply with the applicable local explosion protection regulations. ▸ Observe the information in the data sheet and on the name plates of pump and motor.
	<p>⚠ DANGER</p> <p>Persons in the intake chamber during pump set operation Electric shock! Risk of injury!</p> <ul style="list-style-type: none"> ▸ Never start up the pump set when there are persons in the intake chamber.
	<p>⚠ WARNING</p> <p>Impermissible solid objects (tools, screws/bolts or similar) in the pump sump/inlet tank during pump start-up Personal injury and damage to property!</p> <ul style="list-style-type: none"> ▸ Check the pump sump/inlet tank for impermissible solid objects before flooding, and remove, if necessary.

5.2 Checks to be carried out prior to installation

5.2.1 Checking the structural requirements

All structural work required must have been prepared in accordance with the dimensions stated in the outline drawing/general arrangement drawing.

5.2.2 Checking the operating data

Before inserting the pump set into the discharge tube, verify the data on the name plate against the data given in the purchase order and the system data.

Back-up name plate

KSB's scope of supply includes a separate name plate attached to the end of the pump cable which indicates the pump and motor data.

1. Attach this name plate in a clearly visible position outside the discharge tube, e.g. at the control cabinet, pipeline or mounting bracket.

5.2.3 Checking the lubricant of the mechanical seal

The lubricant reservoirs have been filled with an environmentally-friendly, non-toxic lubricant at the factory.

The pump set is supplied in a horizontal position on a suitable transport support.

Visual inspection for signs of oil leakage

1. If no oil leakage is visible in the area of pump casing, impeller or transport support, the lubricant reservoir is filled properly.
2. If oil leakage is visible in the area of pump casing, impeller or transport support, top up the lubricant reservoir.

	<p>⚠ WARNING</p>
	<p>Incorrect installation/placing down Personal injury and damage to property!</p> <ul style="list-style-type: none"> ▷ Position the pump set vertically with the motor on top. ▷ Use appropriate means to secure the pump set against overturning and tipping over. ▷ Refer to the weights given in the data sheet/on the name plate.

- ✓ Signs of oil leakage have been detected.
- 1. Place the pump set in a vertical position. (⇒ Section 3.2.2 Page 11)
- 2. Secure the pump set against tipping over.
- 3. Remove screw plug 903.03 and joint ring 411.03.
- 4. Check the lubricant level.
 - ⇒ If the lubricant level reaches the opening, fit and tighten screw plug 903.03 with joint ring 411.03 again.
 - ⇒ If the lubricant level is below the opening, top up the lubricant. (⇒ Section 7.4.1.4.2 Page 50)
- 5. Fit screw plug 903.03 together with a new joint ring 411.03.

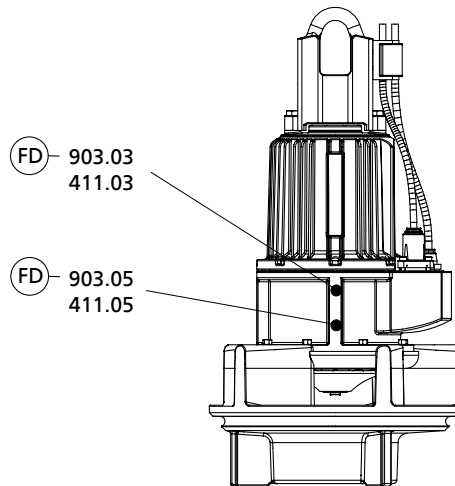

Fig. 6: Checking the lubricant level





903.03 411.03	Lubricant filler opening	903.05 411.05	Lubricant drain
------------------	--------------------------	------------------	-----------------

Table 7: Key to the symbols and codes

Symbol	Description
	Always apply a liquid sealant (e.g. Hylomar SQ32M) to sealing surfaces marked with this symbol.

	<p>NOTE</p>
	<p>If more than 1.5 litres of lubricant are required for topping up, this suggests a defect of the mechanical seals.</p>

5.2.4 Checking the direction of rotation

	<p>⚠ DANGER</p> <p>Pump set running dry Explosion hazard!</p> <ul style="list-style-type: none"> ▶ Check the direction of rotation of explosion-proof pump sets outside potentially explosive atmospheres.
	<p>⚠ WARNING</p> <p>Improper handling when placing the pump set in a vertical/horizontal position Personal injury and damage to property!</p> <ul style="list-style-type: none"> ▶ Depending on the size of the pump (set) use either one or two pieces of lifting equipment. ▶ Use appropriate means to secure the pump set against overturning, tipping over or rolling off. ▶ Maintain adequate safety distance during lifting operations (load may swing when being lifted). ▶ Use additional supports for the transport holder to secure the pump set against overturning.
	<p>⚠ WARNING</p> <p>Improper positioning of pump set when checking the direction of rotation Personal injury and damage to property!</p> <ul style="list-style-type: none"> ▶ Use appropriate means to secure the pump set against overturning or tipping over.
	<p>⚠ WARNING</p> <p>Hands or objects inside the pump casing Risk of injuries, damage to the pump!</p> <ul style="list-style-type: none"> ▶ Never insert your hands or any other objects into the pump. ▶ Check that the inside of the pump is free from any foreign objects. ▶ Take suitable precautions (e.g. wear safety goggles, etc).
	<p>CAUTION</p> <p>Pump set running dry Increased vibrations! Damage to mechanical seals and bearings!</p> <ul style="list-style-type: none"> ▶ Never operate the pump set for more than 60 seconds outside the fluid to be handled.

Check the direction of rotation before installing the pump set, i.e. in dry condition.



1. Place the pump set in a vertical position on a level surface and secure it sufficiently against tipping over.
2. Connect the pump set to the power supply and switch it on.
3. Use one of the two following options to check the direction of rotation:
 - ⇒ 1. When looking at the pump casing from the side, the impeller must turn in clockwise direction.
 - ⇒ 2. Verify the direction of rotation of the impeller against the arrow indicating the direction of rotation on the bearing bracket/bearing housing.
4. If the impeller rotates in the wrong direction of rotation, check and correct the electrical connection and the control system, if applicable. Then check the direction of rotation again.

5. If the direction of rotation is correct, mark which core ends match which of the terminals in the control cabinet.
6. Disconnect the pump set from the power supply and secure it against unintentional start-up.

	<p>⚠ WARNING</p>
	<p>Unintentional starting of pump set Risk of injury by moving parts!</p> <ul style="list-style-type: none"> ▷ Ensure that the pump set cannot be started up unintentionally. ▷ Always make sure the electrical connections are disconnected before carrying out work on the pump set.

5.3 Lowering the pump set into the discharge tube

	<p>⚠ DANGER</p>
	<p>Improper transport Danger to life from falling parts! Damage to the pump set!</p> <ul style="list-style-type: none"> ▷ Use the attachment point provided (pump handle) for attaching lifting accessories. ▷ Never suspend the pump set by its power cable. ▷ Use the lifting chain/rope included in the scope of supply exclusively for lowering/lifting the pump set into/out of the pump sump. ▷ Securely attach the lifting chain/rope to the pump and crane. ▷ Use tested, marked and approved lifting accessories only. ▷ Observe any regional transport regulations. ▷ Observe the product literature supplied by the lifting accessory manufacturer. ▷ The load-carrying capacity of the lifting accessory must be higher than the weight indicated on the name plate of the pump set to be lifted. Take into account any additional system components to be lifted.

 	<p>⚠ DANGER</p>
	<p>Improper installation in potentially explosive atmospheres Explosion hazard! Damage to the pump set!</p> <ul style="list-style-type: none"> ▷ Comply with the applicable local explosion protection regulations. ▷ Observe the information in the data sheet and on the name plates of pump and motor.

	<p>⚠ WARNING</p>
	<p>People falling into the unsecured discharge tube Risk of personal injury!</p> <ul style="list-style-type: none"> ▷ Take suitable precautions during the entire installation/removal process to protect people from falling into the open discharge tube. ▷ Fence off the work area appropriately.

5.3.1 Installation without support rope

	CAUTION
	<p>Incorrect installation Damage to the pump set!</p> <p>▸ Verify that the pump set is correctly seated in the discharge tube.</p>

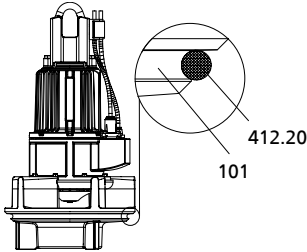

Fig. 7: Inserting the O-ring

Always refer to and comply with the general arrangement drawing/outline drawing when installing the pump set.

1. If O-ring 412.20 is supplied but not fitted, insert it into pump casing 101.
2. Attach the eye hook of the crane to the bail of the pump set.
3. Centre the pump set above the discharge tube. Slowly lower the pump set into the discharge tube until it is seated in the recommended position.
4. Pull the cables up by hand. Fasten them to the sump construction with a cable support sleeve, if required. Do not lift the pump set out of its seat.

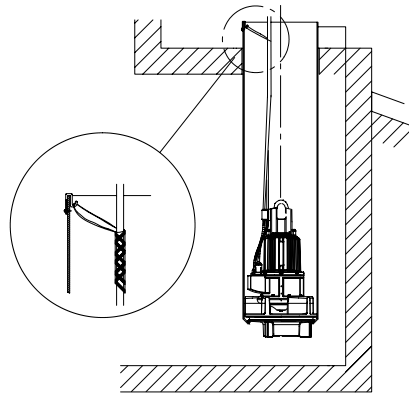

Fig. 8: Fastening the cable support sleeve

5.3.2 Installing the pump set with a support rope

Always refer to and comply with the general arrangement drawing/outline drawing when installing the pump set.

Prior to installing the pump set, visually inspect the support rope. Do not exceed the permissible load-carrying capacity.

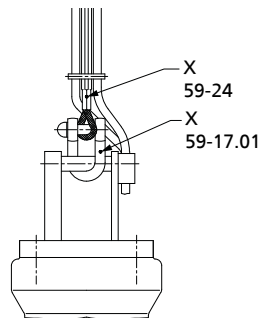



Fig. 9: X = indication of load-carrying capacity

59-24	Support rope
59-17.01	Shackle

	CAUTION
	<p>Incorrect installation Damage to the pump set!</p> <p>▸ Verify that the pump set is correctly seated in the discharge tube.</p>

	<p style="background-color: yellow; margin: 0;">CAUTION</p> <p>Pump set drops during the installation or removal process Damage to the machinery and system!</p> <ul style="list-style-type: none"> ▶ Never use the turnbuckle or shackle to lift the pump set. ▶ Always use lifting lug 59-47. (⇒ Section 9.3 Page 68)
	<p style="background-color: #0056b3; color: white; margin: 0;">NOTE</p> <p>Prior to fitting the turnbuckle, check that the corresponding split pin has not been cracked or chipped. If damaged, always use a new split pin.</p>

- ✓ Suitably sized lifting equipment is available.
- ✓ The support rope has been visually inspected.
- ✓ The split pin of the turnbuckle has been checked for any damage.

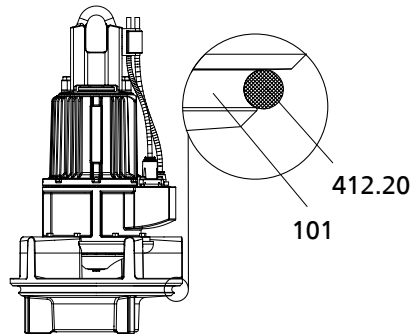

Fig. 10: Inserting the O-ring

1. If O-ring 412.20 is supplied but not fitted, insert it into pump casing 101.

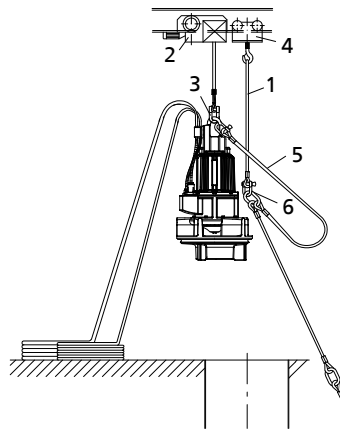

Fig. 11: Lifting and positioning the pump set

2. Secure the lifting chain or rope (1) to the trolley (4) of the lifting equipment (2).
3. Attach the support rope (5) to the bail by its shackle.
For a galvanised shackle, secure the pin at the shackle with Loctite 243.
(⇒ Section 9.3 Page 68)
For a stainless steel shackle, undo and tighten the pin twice and secure it with Loctite 243.
4. Check that the support rope is arranged correctly.
⇒ The free lifting lug (6) has to point away from the pump set
5. Partially unwind the support rope and cables.
6. Lower the pump set into the discharge tube until the bail is in an accessible position, protruding from the discharge tube.
7. Securely cover the discharge tube except for a gap which allows work to continue.

8. Attach the first lifting lug of the support rope (5) to the hoisting rope (1) to securely position the pump set above the discharge tube.
9. Unclip the hook of the lifting equipment from the lifting lug of the support rope and run the lifting equipment to a higher level.

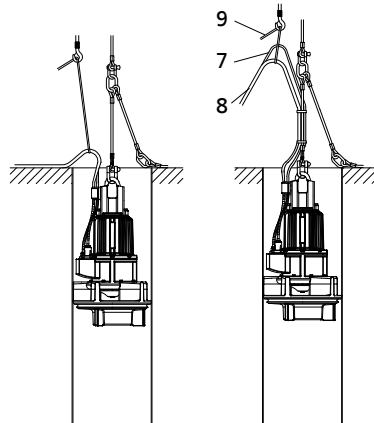

Fig. 12: Securing the control and power cables

10. Secure the control cable (7) and power cables (8) to the eye hook (3) of the lifting equipment with a manila rope (9).
11. Trim spacer (a) to fit between the two ferrules.

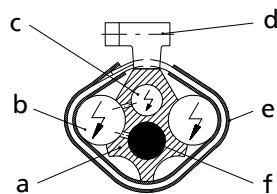

Fig. 13: Cross-section of the cable guide

12. Insert the support rope (f) and the control cable (c) into the spacer (a) and make sure that they are in their respective ducts.
13. Tighten the cables with the manila rope running over the eye hook.
14. Insert the power cables (b) into the hollows of the spacer (a) and, starting from the bottom, firmly clamp the power cables with cable clamps (d) covered by a plastic sheath (e).
15. In the area of the lifting lug between the rope sections, lay all cables in loops and fasten them to the rope section above.
16. Progressively lower the pump set into the discharge tube while securing the cables with evenly spaced sheathed cable clamps.
17. Fit a heat shrink tube on any protruding sharp-edged rope ends (e.g. at the ferrule) to prevent any damage to the power and control cables.

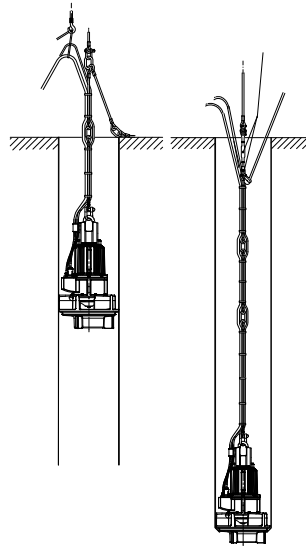

Fig. 14: Lowering the pump set

18. Finally, attach the support rope with shackle and turnbuckle to a suspension loop (provided in the discharge tube or structure). Secure the turnbuckle with a split pin. After inserting the split pin, bend back its two legs.
19. Tighten the turnbuckle until the cables are tight but do not lift the pump off its seat.
20. Unclip the hook of the lifting equipment from the lifting lug, free the cables from the manila rope and route them to the control cabinet.
21. Make sure that the top loose lifting lug is attached to the cables to prevent noise and wear caused by chafing.
22. Remove the safety cover from the discharge tube and mount the discharge tube cover. Seal the cable glands, if any!

5.3.3 Installing the pump set with a support rope and support spacer

Always refer to and comply with the general arrangement drawing/outline drawing when installing the pump set.

Prior to installing the pump set, visually inspect the support rope. Do not exceed the permissible load-carrying capacity.

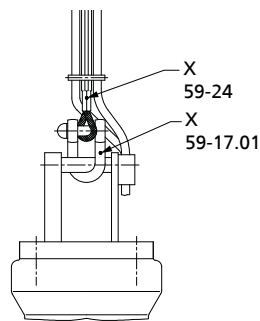

Fig. 15: X = indication of load-carrying capacity

59-24	Support rope
59-17.01	Shackle

	CAUTION
	<p>Incorrect installation Damage to the pump set!</p> <p>▸ Verify that the pump set is correctly seated in the discharge tube.</p>

	<p style="background-color: yellow; margin: 0;">CAUTION</p> <p>Pump set drops during the installation or removal process Damage to the machinery and system!</p> <ul style="list-style-type: none"> ▸ Never use the turnbuckle or shackle to lift the pump set. ▸ Always use lifting lug 59-47. (⇒ Section 9.3 Page 68)
	<p style="background-color: #0056b3; color: white; margin: 0;">NOTE</p> <p>Prior to fitting the turnbuckle, check that the corresponding split pin has not been cracked or chipped. If damaged, always use a new split pin.</p>

- ✓ Suitably sized lifting equipment is available.
- ✓ The support has been supplied pre-assembled and is available for use.
- ✓ The support rope has been visually inspected.
- ✓ The split pin of the turnbuckle has been checked for any damage.

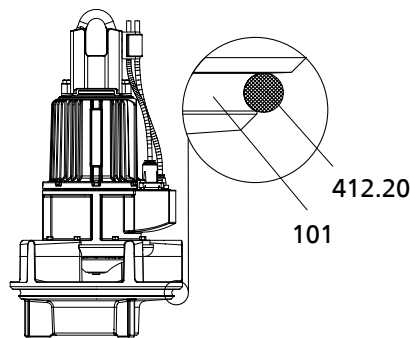

Fig. 16: Inserting the O-ring

1. If O-Ring 412.20 is supplied but not fitted, insert it into pump casing 101.

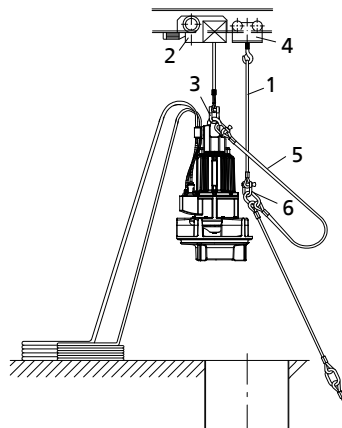

Fig. 17: Lifting and positioning the pump set

2. Secure the lifting chain or rope (1) to the trolley (4) of the lifting equipment (2).
3. Attach the support rope (5) to the bail by its shackle. Check that the support rope is arranged with the lifting lug (6) pointing away from the pump set.
4. Partially unwind the support rope and cables.
5. Lower the pump set into the discharge tube until the bail is in an accessible position, protruding from the discharge tube.
6. Securely cover the discharge tube except for a gap which allows work to continue.
7. Attach the first lifting lug of the support rope (5) to the hoisting rope (1) to securely position the pump set above the discharge tube.

8. Unclip the hook of the lifting equipment from the lifting lug of the support rope and run the lifting equipment to a higher level.

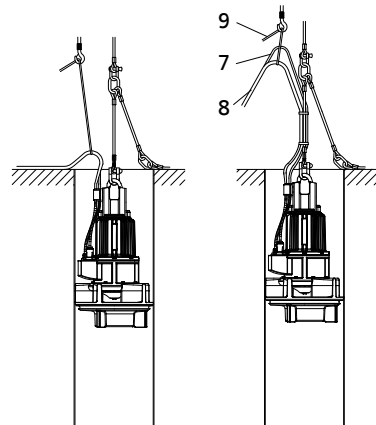

Fig. 18: Securing the control and power cables

9. Secure the control cable (7) and power cables (8) to the eye hook (3) of the lifting equipment with a manila rope (9).
10. Trim spacer (a) to fit between the two ferrules.

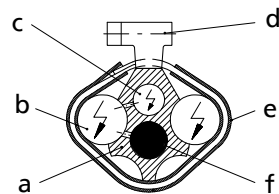

Fig. 19: Cross-section of the cable guide

11. Insert the support rope (f) and the control cable (c) into the spacer (a) and make sure that they are in their respective ducts.
12. Tighten the power cables with the manila rope running over the eye hook.
13. Insert the power cables (b) into the hollows of the spacer (a) and, starting from the bottom, firmly clamp the power cables with cable clamps (d) covered by a plastic sheath (e).
14. Progressively lower the pump set into the discharge tube while securing the cables with evenly spaced sheathed cable clamps.
15. In the area of the lifting lug between the rope sections, lay all power cables in loops and fasten them to the rope section above.
16. Fit a heat shrink tube on any protruding sharp-edged rope ends (e.g. at the ferrule) to prevent any damage to the power and control cables.
17. Trim spacer to suit the position of support 59-7 at the support rope (f) and the type of installation. Insert support rope and control cable (c).
18. Insert the power cables (b) into the hollows of the spacer (a) and firmly clamp the power cables with cable clamps (d).

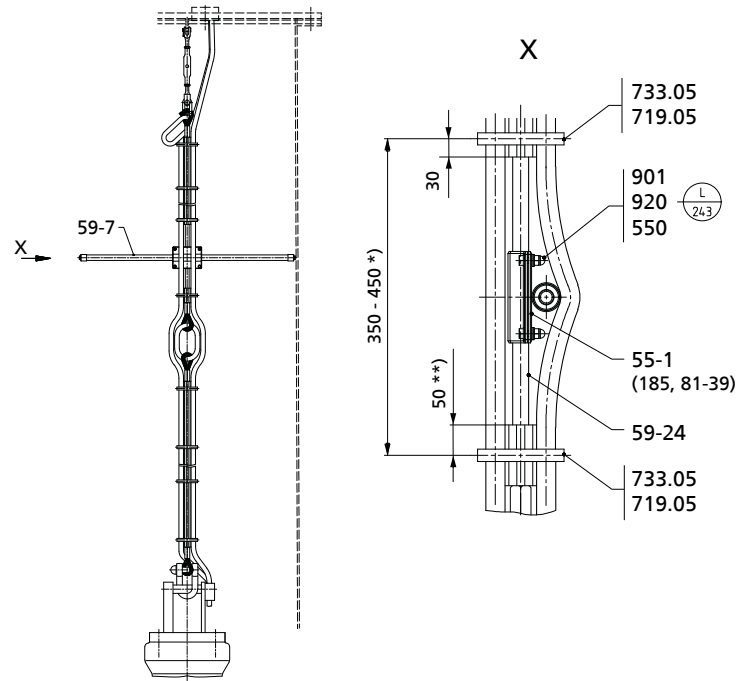

Fig. 20: Support rope with support, dimensions in mm

*) depending on the cable cross-section,

***) for 1 rope or 3 ropes = 30 mm

19. Clamp support 59-7 with guide plate 55-1 to the support rope (f).
20. Undo the screwed connection at the guide plate. Place clamp 81-39 of the guide plate around the support rope.
21. Fasten plate 185 of the guide plate including the rod made of glass fibre reinforced plastics to the clamp with hexagon head bolts 901, discs 550 and cap nuts 920. Tighten the connection and secure it with Loctite 243. (⇒ Section 9.3 Page 68)



NOTE

The support must be clamped firmly to the support rope. If necessary, pad out clamp 81-39.

22. Trim the spacer to fill the space between the two ferrules and accommodate the support.
23. Guide the power and control cables along the support to the next cable clamp. Pull them taught and secure them with the clamp.

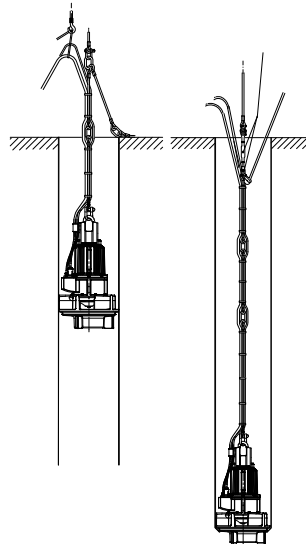

Fig. 21: Lowering the pump set

24. Progressively lower the pump set into the discharge tube. Secure the cables with cable clamps.
25. Finally, attach the support rope with shackle and turnbuckle to a suspension loop (provided in the discharge tube or structure). Secure the turnbuckle with a split pin. After inserting the split pin, bend back its two legs.
26. Tighten the turnbuckle until the cables are tight but do not lift the pump off its seat.
27. Unclip the hook of the lifting equipment from the lifting lug, free the cables from the manila rope and route them to the control cabinet.
28. Make sure that the top loose lifting lug is attached to the cables to prevent noise and wear caused by chafing.
29. Remove the safety cover from the discharge tube and mount the discharge tube cover. Seal the cable glands, if any!

5.4 Electrical system

5.4.1 Information for planning the control system

For the electrical connection of the pump set observe the "Wiring diagrams" section. (⇒ Section 9.4 Page 70)

The pump set is supplied with power cables; it is wired for DOL starting. Star-delta starting is also possible.



NOTE



When laying a cable between the control system and the pump set's connection point, verify that the number of cores is sufficient for the sensors. A minimum cross-section of 1.5 mm² is required.

The motors can be connected to electrical low-voltage grids with rated voltages and voltage tolerances to EN 60038 or to other grids or power supply facilities with a maximum rated voltage tolerance of ± 10 %.

5.4.1.1 Overload protection

1. Protect the pump set against overloading by a thermal time-lag overload protection device in accordance with IEC 60947 and local regulations.
2. Set the overload protection device to the rated current specified on the name plate. (⇒ Section 4.3 Page 16)



5.4.1.2 Level control

	⚠ DANGER
	Pump set running dry Explosion hazard! ▷ Never allow an explosion-proof pump set to run dry!
	CAUTION
	Fluid level below the specified minimum Damage to the pump set by cavitation! ▷ Never allow the fluid level to drop below the specified minimum.

Automatic operation of the pump set in a tank requires the use of level control equipment.
 Observe the minimum fluid level. (⇒ Section 6.2.4.3 Page 40)

5.4.1.3 Operation on a frequency inverter

The pump set is suitable for operation on a frequency inverter as per IEC 60034-17.

	⚠ DANGER
	Operation outside the permitted frequency range Explosion hazard! ▷ Never operate an explosion-proof pump set outside the specified range.
	⚠ DANGER
	Incorrect selection and setting of the frequency inverter Explosion hazard! ▷ Observe the following information on selecting and setting a frequency inverter.

- Selection** When selecting a frequency inverter, check the following details:
 - Data provided by the manufacturer
 - Electrical data of the pump set, particularly the rated current
 - Only voltage source inverters (VSI) with pulse width modulation (PWM) and carrier frequencies between 1 and 16 kHz are suitable.
- Setting** Observe the following instructions for setting a frequency inverter:
 - Set the current limit to max. 1.2 times the rated current indicated on the name plate.
- Start-up** Observe the following instructions for starting the frequency inverter:
 - Ensure short start ramps (maximum 5 seconds).
 - Only start variable speed control after 2 minutes at the earliest.
 Pump start-up with long start ramps and low frequency may cause clogging.
- Operation** Observe the following limits during operation on a frequency inverter:
 - Only utilise up to 95 % of the motor rating P_2 indicated on the name plate.
 - Frequency range 25 to 50 Hz

Electromagnetic compatibility Operation on a frequency inverter produces interference emissions whose level varies depending on the inverter used (type, interference suppression, make). To prevent the drive system, consisting of a submersible motor and a frequency inverter, from exceeding any given limits always observe the EMC information provided by the inverter manufacturer. If the inverter manufacturer recommends a shielded power cable, make sure to use a submersible motor pump with shielded power cables.

Interference immunity

The submersible motor pump generally meets interference immunity requirements. For monitoring the sensors installed the operator must ensure sufficient interference immunity by appropriately selecting and laying the power cables in the plant. No modifications are required on the power/control cable of the submersible motor pump. Suitable analysing devices must be selected. To monitor the leakage sensor inside the motor using a special relay available from KSB is recommended.

5.4.1.4 Sensors

	<p>⚠ DANGER</p> <p>Operating an incompletely connected pump set Explosion hazard! Damage to the pump set!</p> <ul style="list-style-type: none"> ▶ Never start up a pump set with incompletely connected power connection cables or non-operational monitoring devices.
---	--

	<p>CAUTION</p> <p>Incorrect wiring Damage to the sensors!</p> <ul style="list-style-type: none"> ▶ Observe the limits stated in the following sections of this manual when connecting the sensors.
---	---

The pump set features sensors designed to prevent hazards and damage to the pump set.

Measuring transducers are required for analysing the sensor signals supplied. Suitable devices for 230 V AC can be supplied by KSB.

	<p>NOTE</p> <p>Reliable and safe operation of the pump within the scope of our warranty is only possible if the sensor signals are properly analysed as stipulated in this manual.</p>
---	---

All sensors are located inside the pump set and are connected to the power cable. For information on wiring and core identification please refer to the "Wiring diagrams" section. The individual sensors and the limit values to be set are described in the following sections.

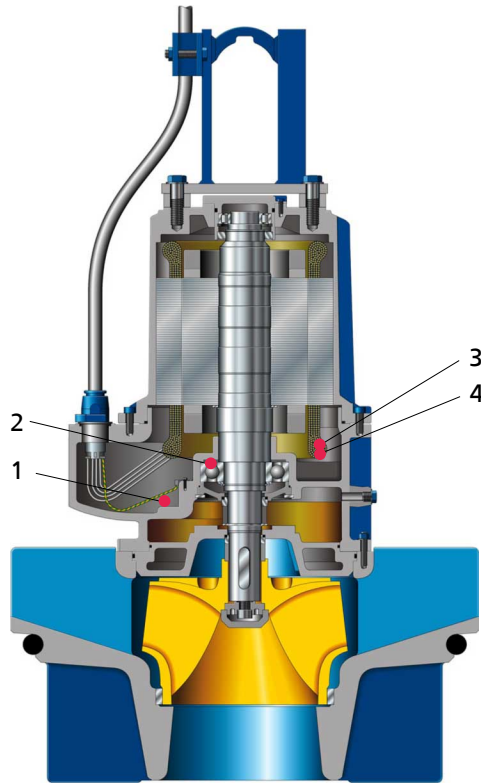



Fig. 22: Sensor positions

Position	Sensor	Standard		Optional
		Motor version U	Motor version X	
1	Leakage inside the motor (connection and winding space)	X	X	-
2	Bearing temperature (lower bearings)	-	-	X
3	Motor temperature (bimetal)	X	X	-
4	Motor temperature (PTC)	X	X	-

5.4.1.4.1 Motor temperature

 	<p>⚠ DANGER</p>
<p>Insufficient cooling conditions Explosion hazard! Winding damage!</p> <ul style="list-style-type: none"> ▶ Never operate a pump set without operational temperature monitoring. ▶ For explosion-proof pump sets use a thermistor tripping unit with manual reset and ATEX approval for monitoring the temperature of explosion-proof motors in "flameproof enclosure" Ex d type of protection. 	

The pump set features double monitoring of the winding temperature. Two bimetal switches (terminals 21 and 22, max. 250 V~/2 A) serve as temperature control devices which open when the winding temperature is too high. Tripping must result in the pump set cutting out. Automatic re-start is permissible.

For explosion-proof pump sets, the three additional, series-connected (PTC) thermistors with terminals 10 and 11 must be used. They must be connected to a thermistor tripping unit with manual reset and ATEX approval for monitoring the temperature of explosion-proof motors with "flameproof enclosure" Ex d type of protection.

5.4.1.4.2 Leakage inside the motor

	⚠ DANGER
	<p>Incorrect monitoring of leakage electrode Explosion hazard! Danger of death from electric shock!</p> <p>▷ Voltages must be < 30 V AC and tripping currents < 0.5 mA.</p>

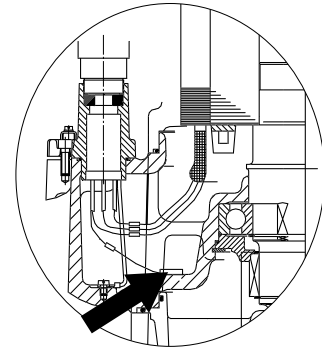
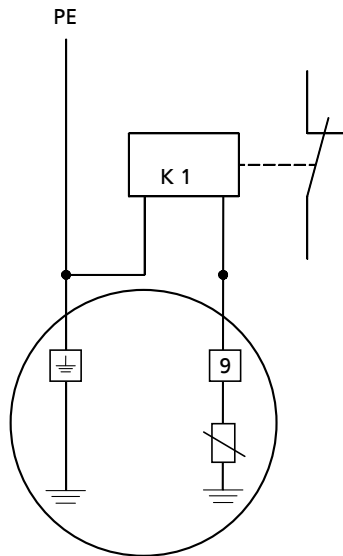

Wiring of the electrode relay (standard) Position of the electrodes in the motor housing

An electrode fitted inside the motor monitors the winding space (B2) for leakage. The electrode is intended for connection to an electrode relay (conductor marking 9). Tripping of the electrode relay must result in the pump set cutting out.

The electrode relay (K1) must fulfil the following requirements:

- Sensor circuit 10 to 30 V AC
- Tripping current ≤ 0.5 mA

5.4.1.4.3 Bearing temperature

As an option, the pump set can be supplied with temperature monitoring in the area of the pump-end bearing. Check in the data sheet whether the pump set is equipped with bearing temperature monitoring.









The bearing temperature sensor is a Pt100 resistance thermometer. It must be connected to a temperature control device with a Pt100 input and 2 separate outputs for two different switching points (sensor circuit maximum 6 V/2 mA).

Set the following limits:

- Alert at 110 °C
- Cut-out of the pump set at 130 °C

5.4.2 Electrical connection

	⚠ DANGER
	<p>Electrical connection work by unqualified personnel Danger of death from electric shock!</p> <p>▷ Always have the electrical connections installed by a trained and qualified electrician.</p> <p>▷ Observe regulations IEC 60364 and, for explosion-proof models, EN 60079.</p>

	<p>⚠ WARNING</p> <p>Incorrect connection to the mains Damage to the mains network, short circuit!</p> <ul style="list-style-type: none"> ▸ Observe the technical specifications of the local energy supply companies.
	<p>CAUTION</p> <p>Improper routing of power cable Damage to the power cables!</p> <ul style="list-style-type: none"> ▸ Never move the power cables at temperatures below - 25 °C. ▸ Never kink or crush the power cables. ▸ Never lift the pump set by the power cables. ▸ Adjust the length of the power cables to the site requirements.
	<p>CAUTION</p> <p>Motor overload Damage to the motor!</p> <ul style="list-style-type: none"> ▸ Protect the motor by a thermal time-lag overload protection device in accordance with IEC 60947 and local regulations.
<p>(⇒ Section 5.4.1 Page 31) For electrical connection observe the wiring diagrams in the Annex and the information for planning the control system.</p> <p>The pump set is supplied with a connection cable. Always connect all marked cores.</p>	
	<p>⚠ DANGER</p> <p>Incorrect wiring Explosion hazard!</p> <ul style="list-style-type: none"> ▸ The connection point of the cable ends must be located outside of the potentially explosive atmosphere or inside electrical equipment approved to equipment category II2G.
 	<p>⚠ DANGER</p> <p>Operating an incompletely connected pump set Explosion hazard! Damage to the pump set!</p> <ul style="list-style-type: none"> ▸ Never start up a pump set with incompletely connected power connection cables or non-operational monitoring devices.
	<p>⚠ DANGER</p> <p>Connection of damaged power cables Danger of death from electric shock!</p> <ul style="list-style-type: none"> ▸ Check the power cables for damage before connecting them. ▸ Never connect damaged power cables. ▸ Replace damaged power cables.
	<p>CAUTION</p> <p>Flow-induced motion Damage to the power cable!</p> <ul style="list-style-type: none"> ▸ Run the power cable upwards without slack.

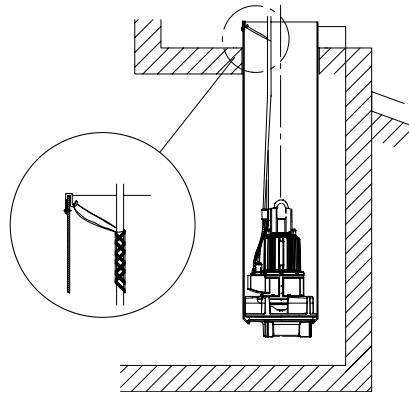

Fig. 23: Fastening the connection cable

1. Run the power cables upwards without slack and fasten them.
2. Only remove the protective caps from the power cables immediately before connecting the cables.
3. If necessary, adjust the length of the power cables to the site requirements.
4. After shortening the cables, correctly re-affix the markings on the individual conductors at the cable ends.



Potential equalisation The pump set does not have an external PE connection (risk of corrosion).

	<p>⚠ DANGER</p>
	<p>Incorrect wiring Explosion hazard!</p> <ul style="list-style-type: none"> ▸ Explosion-proof pump sets installed in a tank must never be retrofitted with an external potential equalisation connection!
	<p>⚠ DANGER</p>
	<p>Touching the pump set during operation Electric shock!</p> <ul style="list-style-type: none"> ▸ Make sure that the pump set cannot be touched during operation.

6 Commissioning/Start-up/Shutdown

6.1 Commissioning/start-up

6.1.1 Prerequisites for commissioning/start-up

	<div style="background-color: #e67e22; color: white; padding: 5px;">⚠ DANGER</div> <p>Persons in the tank during pump operation Electric shock! Risk of injury! Danger of death from drowning!</p> <ul style="list-style-type: none"> ▶ Never start up the pump set without special protective equipment when there are persons in the tank. ▶ If persons come into contact with the fluid handled during pump operation (e.g. in sports facilities and leisure parks), the plant designer/operator must comply with the legal requirements. Special electrical and mechanical protective equipment compliant with the legal regulations must be provided.
	<div style="background-color: #f1c40f; color: white; padding: 5px;">⚠ WARNING</div> <p>People falling into the unsecured discharge tube Risk of personal injury!</p> <ul style="list-style-type: none"> ▶ Take suitable precautions during the entire installation/removal process to protect people from falling into the open discharge tube. ▶ Fence off the work area appropriately.

Before commissioning/starting up the pump set, make sure that the following conditions are met:

- The lubricant has been checked.
- The direction of rotation has been checked.
- The pump set has been properly connected to the power supply and is equipped with all protection devices.
- The pump set has been installed in the discharge tube as described in this manual.
- The minimum fluid level has been reached.
- After prolonged shutdown of the pump (set), the activities required for returning the pump (set) to service have been carried out. (⇒ Section 6.4 Page 42)
- Safety-relevant protective equipment must be installed and fully functional.

6.1.2 Start-up

	<div style="background-color: #e67e22; color: white; padding: 5px;">⚠ DANGER</div> <p>Persons in the tank during pump operation Electric shock! Risk of injury! Danger of death from drowning!</p> <ul style="list-style-type: none"> ▶ Never start up the pump set without special protective equipment when there are persons in the tank. ▶ If persons come into contact with the fluid handled during pump operation (e.g. in sports facilities and leisure parks), the plant designer/operator must comply with the legal requirements. Special electrical and mechanical protective equipment compliant with the legal regulations must be provided.
---	---

	CAUTION
	<p>Re-starting while motor is still running down Damage to the pump set!</p> <ul style="list-style-type: none"> ▸ Do not re-start the pump set before it has come to a standstill. ▸ Never start up the pump set while the pump is running in reverse.

✓ The fluid level is sufficiently high.

	CAUTION
	<p>Start-up against a closed shut-off element Damage to the pump set!</p> <ul style="list-style-type: none"> ▸ Never operate the pump set against a closed shut-off element.

1. Fully open the discharge line shut-off element, if any.
2. Start up the pump set.

6.2 Operating limits

	⚠ DANGER
	<p>Non-compliance with operating limits Damage to the pump set!</p> <ul style="list-style-type: none"> ▸ Comply with the operating data indicated in the data sheet. ▸ Avoid operation below Q_{min}. ▸ Never operate an explosion-proof pump set at ambient or fluid temperatures exceeding those specified in the data sheet or on the name plate. ▸ Never operate the pump set outside the limits specified below.

6.2.1 Supply voltage

	⚠ DANGER
	<p>Non-compliance with permissible supply voltage tolerances Explosion hazard</p> <ul style="list-style-type: none"> ▸ Never operate an explosion-proof pump (set) outside the specified range.

The maximum permissible deviation in supply voltage is $\pm 10\%$ of the rated voltage. The voltage difference between the individual phases must not exceed 1 %.

6.2.2 Frequency of starts

	CAUTION
	<p>Excessive frequency of starts Risk of damage to the motor!</p> <ul style="list-style-type: none"> ▸ Never exceed the specified frequency of starts.

To prevent high temperature increases in the motor and excessive loads on the motor, seal elements and bearings, the frequency of starts shall not exceed 10 start-ups per hour.

These values apply to mains start-up (DOL or with star-delta contactor, autotransformer, soft starter). This limitation does not apply to operation on a frequency converter.

	CAUTION
	<p>Re-starting while motor is still running down Damage to the pump set!</p> <ul style="list-style-type: none"> ▷ Do not re-start the pump set before it has come to a standstill. ▷ Never start up the pump set while the pump is running in reverse.

6.2.3 Operation on a frequency inverter

	⚠ DANGER
	<p>Operation outside the permitted frequency range Explosion hazard!</p> <ul style="list-style-type: none"> ▷ Never operate an explosion-proof pump set outside the specified range.

Frequency inverter operation of the pump set is permitted in the frequency range from 25 to 50 Hz.

6.2.4 Fluid handled

6.2.4.1 Temperature of the fluid handled

The pump set is designed for transporting liquids. The pump set is not operational under freezing conditions.

	CAUTION
	<p>Danger of frost/freezing Damage to the pump set!</p> <ul style="list-style-type: none"> ▷ Drain the pump set or protect it against freezing.

Refer to the maximum permissible fluid and ambient temperature on the name plate and in the data sheet.

6.2.4.2 Density of the fluid handled

The pump input power changes in proportion to the density of the fluid handled.

	CAUTION
	<p>Impermissibly high density of the fluid handled Motor overload!</p> <ul style="list-style-type: none"> ▷ Observe the information on fluid density in the data sheet. ▷ Make sure the motor has sufficient power reserves.

6.2.4.3 Minimum level of fluid handled

	⚠ DANGER
	<p>Pump set running dry Explosion hazard!</p> <ul style="list-style-type: none"> ▷ Never allow an explosion-proof pump set to run dry!

	CAUTION
	<p>Fluid level below the specified minimum Damage to the pump set by cavitation!</p> <ul style="list-style-type: none"> ▷ Never allow the fluid level to drop below the specified minimum.

The pump set is ready for operation when the fluid level has reached dimension "t," as a minimum.

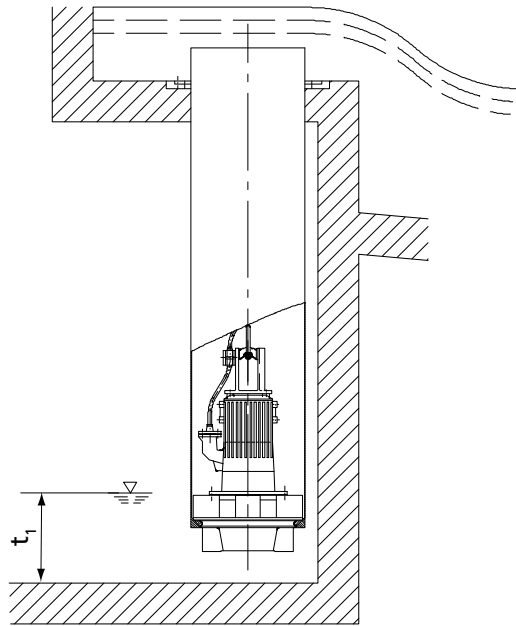

Fig. 24: Minimum level of fluid handled

6.2.4.4 Abrasive fluids

Do not exceed the maximum permissible solids content specified in the data sheet. When the pump handles fluids containing abrasive substances, increased wear of the hydraulic system and shaft seal are to be expected. In this case, reduce the commonly recommended inspection intervals.



6.3 Shutdown/storage/preservation

6.3.1 Shutdown

	CAUTION
	<p>Uncontrolled backflow of the fluid from the riser Damage to the pump set!</p> <ul style="list-style-type: none"> ▷ Prevent any uncontrolled backflow of the fluid handled with suitable means. ▷ Control the fluid backflow, e.g. by throttling the gate valve in the discharge line.

6.3.2 Measures to be taken for shutdown

	⚠ WARNING
	<p>Unintentional starting of pump set Risk of injury by moving parts!</p> <ul style="list-style-type: none"> ▷ Ensure that the pump set cannot be started up unintentionally. ▷ Always make sure the electrical connections are disconnected before carrying out work on the pump set.

	<p>⚠ WARNING</p> <p>Fluids, consumables and supplies which are hot and/or pose a health hazard Risk of injury!</p> <ul style="list-style-type: none"> ▷ Observe all relevant laws. ▷ When draining the fluid take appropriate measures to protect persons and the environment. ▷ Decontaminate pumps which handle fluids posing a health hazard.
	<p>CAUTION</p> <p>Danger of frost/freezing Damage to the pump set!</p> <ul style="list-style-type: none"> ▷ If there is any danger of frost/freezing, remove the pump set from the fluid handled and clean, preserve and store it.

The pump set remains installed

- ✓ Make sure sufficient fluid is available for the operation check run of the pump set.
- 1. For prolonged shutdown periods, start up the pump set regularly once every three months. Let it run for about one minute.
This will prevent the formation of deposits within the pump and the pump intake area.



The pump (set) is removed from the pipe and stored

- ✓ All safety regulations are observed. (⇒ Section 7.1 Page 43)
- 1. Clean the pump set.
- 2. Preserve the pump set.

6.4 Returning to service

For returning the pump set to service observe the sections on commissioning/start-up and operating limits.







For returning the pump set to service after storage also follow the instructions for maintenance/inspection. (⇒ Section 7.2 Page 44)

	<p>⚠ WARNING</p> <p>Failure to re-install or re-activate protective devices Risk of personal injury from moving parts or escaping fluid!</p> <ul style="list-style-type: none"> ▷ As soon as the work is complete, re-install and/or re-activate any safety-relevant and protective devices.
	<p>NOTE</p> <p>On pumps/pump sets older than 5 years we recommend replacing all elastomer seals.</p>

7 Servicing/Maintenance

7.1 Safety regulations

The operator ensures that maintenance, inspection and installation is performed by authorised, qualified specialist personnel who are thoroughly familiar with the manual.

	<p>⚠ DANGER</p> <p>Sparks produced during servicing work Explosion hazard!</p> <ul style="list-style-type: none"> ▷ Observe the safety regulations in force at the place of installation! ▷ Never open an energised pump set. ▷ Always perform maintenance work on explosion-proof pump sets outside potentially explosive atmospheres only.
	<p>⚠ DANGER</p> <p>Risk of falling when working at great heights Danger to life by falling from a great height!</p> <ul style="list-style-type: none"> ▷ Pay attention to safety equipment, such as railings, covers, barriers, etc. ▷ Observe the applicable local occupational safety and accident prevention regulations.
	<p>⚠ WARNING</p> <p>Unintentional starting of pump set Risk of injury by moving parts!</p> <ul style="list-style-type: none"> ▷ Ensure that the pump set cannot be started up unintentionally. ▷ Always make sure the electrical connections are disconnected before carrying out work on the pump set.
	<p>⚠ WARNING</p> <p>Hands, other body parts or foreign objects in the propeller or propeller intake area Risk of injury! Damage to the submersible motor pump!</p> <ul style="list-style-type: none"> ▷ Never insert your hands, other body parts or foreign objects into the propeller or propeller intake area. ▷ Check that the propeller can rotate freely.
	<p>⚠ WARNING</p> <p>Fluids, consumables and supplies which are hot and/or pose a health hazard Risk of injury!</p> <ul style="list-style-type: none"> ▷ Observe all relevant laws. ▷ When draining the fluid take appropriate measures to protect persons and the environment. ▷ Decontaminate pumps which handle fluids posing a health hazard.
	<p>⚠ WARNING</p> <p>Hot surface Risk of injury!</p> <ul style="list-style-type: none"> ▷ Allow the pump set to cool down to ambient temperature.

	<p>⚠ WARNING</p>
	<p>Improper lifting/moving of heavy assemblies or components Personal injury and damage to property!</p> <ul style="list-style-type: none"> ▶ Use suitable transport devices, lifting equipment and lifting tackle to move heavy assemblies or components.

	<p>⚠ WARNING</p>
	<p>Insufficient stability Risk of crushing hands and feet!</p> <ul style="list-style-type: none"> ▶ During assembly/dismantling, secure the pump (set)/pump parts to prevent tipping or falling over.

	<p>NOTE</p>
	<p>Special regulations apply to repair work on explosion-proof pump sets. Modification or alteration of the pump set may affect explosion protection and are only permitted after consultation with the manufacturer.</p>

A regular maintenance schedule will help avoid expensive repairs and contribute to trouble-free, reliable operation of the pump, pump set and pump parts with a minimum of servicing/maintenance expenditure and work.

	<p>NOTE</p>
	<p>All maintenance, service and installation work can be carried out by KSB Service or authorised workshops. For contact details please refer to the enclosed "Addresses" booklet or visit "www.ksb.com/contact" on the Internet.</p>

Never use force when dismantling and reassembling the pump set.

7.2 Maintenance/inspection

KSB recommends the following regular maintenance schedule:

Table 8: Overview of maintenance work

Maintenance interval	Servicing/maintenance work	For details see ...
Every 4,000 h, at least once a year	Measure the insulation resistance.	(⇒ Section 7.2.1.1 Page 44)
Every 10,000 hours, at least every 3 years	Check the cables.	(⇒ Section 7.3.3 Page 47)
	Check the earth conductor.	(⇒ Section 7.3.4 Page 47)
	Check the sensors.	(⇒ Section 7.2.1.2 Page 45)
	Change the lubricant.	(⇒ Section 7.4.1.4 Page 49)
Every 5 years	General overhaul	

On material variant G3 the sacrificial anodes must initially be checked after 6 months. If necessary, replace the anodes. If the anodes show little wear the maintenance interval can be extended to 12 months.

7.2.1 Inspection work

7.2.1.1 Measuring the insulation resistance

Measure the insulation resistance of the motor winding during annual maintenance work.

- ✓ The pump set has been disconnected in the control cabinet.
- ✓ Use an insulation resistance measuring device.
- ✓ The recommended measuring voltage equals 500 V (maximum permissible 1000 V).

1. Measure the winding to chassis ground.
To do so, connect all winding ends together.
 2. Measure the winding temperature sensors to chassis ground.
To do so, connect all core ends of the winding temperature sensors together and connect all winding ends to chassis ground.
- ⇒ The insulation resistance of the core ends to chassis ground must not be lower than 1 MΩ.
If the resistance measured is lower, power cable and motor resistance must be measured separately. Disconnect the power cable from the motor for this purpose.

	NOTE
	If the insulation resistance of the power cable is lower than 1 MΩ, the power cable is defective and must be replaced.

	NOTE
	If the insulation resistance values measured on the motor are too low, the winding insulation is defective. The pump set must not be returned to service in this case.

7.2.1.2 Checking the sensors

	CAUTION
	Excessive test voltage Damage to the sensors! ▶ Use a commercially available ohmmeter to measure the resistance.

The tests described below measure the resistance at the core ends of the control cable. The actual sensor function is not tested.

The sensors supplied with the pump set may not include the maximum scope of supply described in this section.

Temperature sensors in the motor winding

Table 9: Resistance measurement

Measurement between terminals ...	Resistance
	[Ω]
21 and 22	< 1
10 and 11	200 to 750

If the specified tolerances are exceeded, disconnect the power cable at the pump set and repeat the check inside the motor.

If the tolerances are exceeded here, too, the motor section has to be opened and overhauled. The temperature sensors are fitted in the stator winding and cannot be replaced.

Leakage sensor in the motor

Table 10: Resistance measurement of the leakage sensor in the motor

Measurement between terminals ...	Resistance
	[kΩ]
9 and earth conductor (PE)	> 60

Lower resistance values suggest water ingress into the motor. In this case the motor section must be opened and overhauled.

Bearing temperature sensor (optional)

Table 11: Resistance measurement of the bearing temperature sensor

Measurement between terminals ...	Resistance
	[Ω]
15 and 16	100 - 120

7.3 Removing the pump set

7.3.1 Removing the pump set

	⚠ DANGER
	<p>Insufficient preparation of work on the pump (set) Risk of injury!</p> <ul style="list-style-type: none"> ▷ Properly shut down the pump set. ▷ Close the shut-off elements in suction and discharge line. ▷ Drain the pump and release the pump pressure. ▷ Close any auxiliary connections. ▷ Allow the pump set to cool down to ambient temperature.

	⚠ WARNING
	<p>People falling into the unsecured discharge tube Risk of personal injury!</p> <ul style="list-style-type: none"> ▷ Take suitable precautions during the entire installation/removal process to protect people from falling into the open discharge tube. ▷ Fence off the work area appropriately.

	⚠ WARNING
	<p>Turnbuckle and shackle are not suitable for lifting the pump set Risk of injury! Damage to the pump set!</p> <ul style="list-style-type: none"> ▷ Always use the lifting lugs of the support rope to lift the pump set.

- ✓ The power cables have been disconnected and secured against unintentional start-up.
 - ✓ The discharge tube is open; its opening is securely covered except for a gap allowing work to continue.
 - ✓ Suitable lifting equipment is provided.
1. Attach the hoisting chain or rope to the trolley.
 2. Free the uppermost lifting lug from the cables, attach it to the eye hook and run the lifting equipment to a higher level.
 3. Open and disconnect the turnbuckle.

	NOTE
	<p>Prevent any loose parts from falling into the pump sump!</p>

4. Pull the pump set up until it reaches the second lifting lug of the cables.
5. Attach the hoisting chain or rope with the shackle to the first lifting lug (together with the eye hook).
6. Unclip the eye hook and attach it to the second lifting lug.
7. Pull the pump set up until it reaches the third lifting lug. Free the hoisting chain or rope from the first lifting lug and attach it to the third lifting lug.
8. Pull the pump set up until it reaches the fourth lifting lug. Unclip the eye hook and attach it to the fourth lifting lug.
9. Repeat this procedure until the pump bail is located above the discharge tube, then attach it to the eye hook.
10. Remove the safety cover from the discharge tube.

11. Extract the pump set from the discharge tube, move it sideways and set it down.

	⚠ WARNING
	<p>Pump set tipping over Risk of squashing hands and feet!</p> <ul style="list-style-type: none"> ▷ Suspend or support the pump set.

	CAUTION
	<p>Improper storage Damage to the power cables!</p> <ul style="list-style-type: none"> ▷ Support the power cables at the cable entry to prevent permanent deformation. ▷ Protect the core ends against moisture.

12. To prevent the pump set from tipping over, do not disconnect it from the hook of the lifting equipment.

13. Clean the pump set (e.g. with water).

14. Collect and properly dispose of any cleaning liquid.

7.3.2 Drainage/cleaning

	⚠ WARNING
	<p>Fluids, consumables and supplies which are hot and/or pose a health hazard Hazard to persons and the environment!</p> <ul style="list-style-type: none"> ▷ Collect and properly dispose of flushing fluid and any residues of the fluid handled. ▷ Wear safety clothing and a protective mask, if required. ▷ Observe all legal regulations on the disposal of fluids posing a health hazard.

1. Always flush the pump if it has been used for handling noxious, explosive, hot or other hazardous fluids.

2. Always flush and clean the pump before transporting it to the workshop. Provide a certificate of decontamination for the pump set. (⇒ Section 11 Page 86)

7.3.3 Checking the cables

When removing the pump set from the discharge tube, check the hoisting rope and the cables for any damage. Replace any damaged components by original spare parts.

Longer sections of combined cables must be dismantled:

1. Remove the cables from the cable clamps.
2. Remove the spacer.
3. Roll up the cables and place them next to the pump set.
4. Undo the shackle to separate the support rope from the pump set.

7.3.4 Checking the earth conductor

1. Measure the resistance between earth conductor and earth. The resistance must be below 1 Ω.
2. Replace any damaged components by original spare parts.

	⚠ DANGER
	Defective earth conductor Electric shock! ▶ Never switch on a pump set with a defective earth conductor.

7.4 Lubrication and lubricant change

7.4.1 Lubricating the mechanical seal

The mechanical seal is supplied with lubricant from the lubricant reservoir.

7.4.1.1 Intervals

Replace the lubricant every 10,000 operating hours but at least every 3 years.
 (⇒ Section 7.2 Page 44)

7.4.1.2 Lubricant quality

The lubricant reservoir is filled at the factory with an environmentally friendly, non-toxic lubricant of medical quality (unless otherwise specified by the customer). The following lubricants can be used to lubricate the mechanical seals:

Table 12: Lubricant quality

Code	Properties	
Paraffin oil or white oil. Alternative: motor oil grades SAE 10W to SAE 20W	Kinematic viscosity at 40 °C	< 20 mm ² /s
	Flash point (to Cleveland)	> 160 °C
	Solidification point (pour point)	< -15 °C

Recommended lubricants:

- Merkur WOP 40 PB, made by SASOL
- Merkur white oil Pharma 40, made by DEA
- Thin-bodied paraffin oil No. 7174, made by Merck
- Equivalent brands of medical quality, non-toxic
- Water-glycol mixture

	⚠ WARNING
	Lubricant contaminating fluid handled Hazard to persons and the environment! ▶ Using machine oil is only permitted if the oil is disposed of properly.

7.4.1.3 Lubricant quantity

Table 13: Lubricant quantity [l] depending on motor

Motor	Lubricant quantity
	[l]
29 4	4,5
20 6, 26 6	
10 8, 17 8, 21 8	
35 4, 50 4, 65 4	
32 6, 40 6, 50 6	6,5
26 8, 35 8	

7.4.1.4 Changing the lubricant

	<p>⚠ WARNING</p>
	<p>Lubricants posing a health hazard and/or hot lubricants Hazard to persons and the environment!</p> <ul style="list-style-type: none"> ▷ When draining the lubricant take appropriate measures to protect persons and the environment. ▷ Wear safety clothing and a protective mask, if required. ▷ Collect and dispose of any lubricants. ▷ Observe all legal regulations on the disposal of fluids posing a health hazard.
	<p>⚠ WARNING</p>
	<p>Excess pressure inside the pump set Risk of injury when opening the pump set!</p> <ul style="list-style-type: none"> ▷ Take care when opening the inner chambers. Equalise the pressure.
	<p>⚠ WARNING</p>
	<p>Improper handling when placing the pump set in a vertical/horizontal position Personal injury and damage to property!</p> <ul style="list-style-type: none"> ▷ Depending on the size of the pump (set) use either one or two pieces of lifting equipment. ▷ Use appropriate means to secure the pump set against overturning, tipping over or rolling off. ▷ Maintain adequate safety distance during lifting operations (load may swing when being lifted). ▷ Use additional supports for the transport holder to secure the pump set against overturning.

7.4.1.4.1 Draining the lubricant

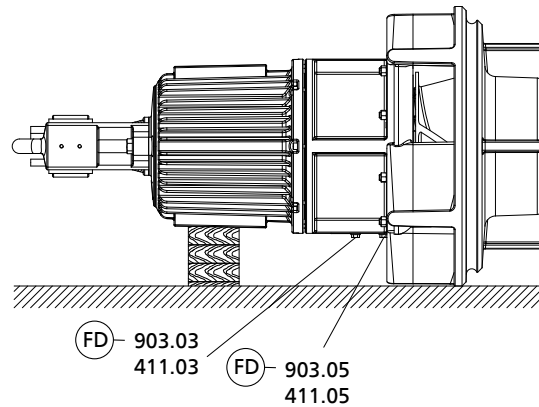

Fig. 25: Draining the lubricant

903.03 411.03	Lubricant filler opening	903.05 411.05	Lubricant drain
------------------	--------------------------	------------------	-----------------

Table 14: Key to the symbols and codes

Symbol	Description
(FD)	Always apply a liquid sealant (e.g. Hylomar SQ32M) to sealing surfaces marked with this symbol.

- ✓ The pump set is positioned horizontally on a clean and level surface and is protected against rolling off.
- ✓ A suitable container for collecting the lubricant is on hand.

1. Place a suitable container under screw plug 903.05.
2. Undo and remove screw plug 903.03 with joint ring 411.03. Observe the plate "Oil filler plug".
3. Undo and remove screw plug 903.05 with joint ring 411.05. Observe the plate "Oil drain".
4. Drain the lubricant and dispose of it properly.
5. Apply a thread-locking agent to screw plug 903.05 and screw it back in together with new joint ring 411.05.

7.4.1.4.2 Filling in the lubricant

	⚠ WARNING
	<p>Incorrect installation/placing down Personal injury and damage to property!</p> <ul style="list-style-type: none"> ▷ Position the pump set vertically with the motor on top. ▷ Use appropriate means to secure the pump set against overturning and tipping over. ▷ Refer to the weights given in the data sheet/on the name plate.

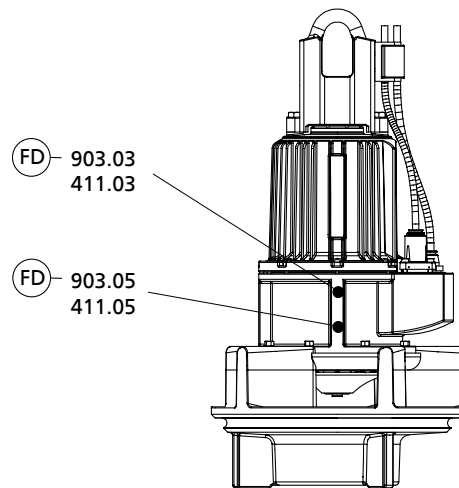

Fig. 26: Filling in the lubricant

903.03 411.03	Lubricant filler opening	903.05 411.05		Lubricant drain
------------------	--------------------------	------------------	--	-----------------

Table 15: Key to the symbols and codes

Symbol	Description
(FD)	Always apply a liquid sealant (e.g. Hylomar SQ32M) to sealing surfaces marked with this symbol.







- ✓ The pump set has been placed in a vertical position on a clean and level surface and protected against tipping over.
1. Fill the lubricant through the lubricant filler opening until the lubricant reservoir overflows. (⇒ Section 7.4.1.3 Page 48)
 2. Apply a thread-locking agent to screw plug 903.03 and screw it back in together with new joint ring 411.03.

7.4.2 Lubricating the rolling element bearings

The pump set is equipped with grease-lubricated, maintenance-free rolling element bearings.

7.5 Dismantling the pump set

7.5.1 General information/Safety regulations

	<p>⚠ DANGER</p> <p>Improper transport Danger to life from falling parts! Damage to the pump set!</p> <ul style="list-style-type: none"> ▸ Use the attachment point provided (eyebolt, lifting lug or bail) for attaching lifting accessories. ▸ Never suspend the pump set by its power cable. ▸ Never use the lifting ropes included in KSB's scope of supply for lifting loads other than the KSB product supplied. ▸ Securely attach the lifting ropes to the pump and crane.
	<p>⚠ WARNING</p> <p>Unqualified personnel performing work on the pump (set) Risk of injury!</p> <ul style="list-style-type: none"> ▸ Always have repair and maintenance work performed by specially trained, qualified personnel.
	<p>⚠ WARNING</p> <p>Hot surface Risk of injury!</p> <ul style="list-style-type: none"> ▸ Allow the pump set to cool down to ambient temperature.
	<p>⚠ WARNING</p> <p>Improper lifting/moving of heavy assemblies or components Personal injury and damage to property!</p> <ul style="list-style-type: none"> ▸ Use suitable transport devices, lifting equipment and lifting tackle to move heavy assemblies or components.
	<p>⚠ WARNING</p> <p>Excess pressure inside the pump set Risk of injury when opening the pump set!</p> <ul style="list-style-type: none"> ▸ Take care when opening the inner chambers. Equalise the pressure.
	<p>⚠ WARNING</p> <p>Components with sharp edges Risk of cutting or shearing injuries!</p> <ul style="list-style-type: none"> ▸ Always use appropriate caution for installation and dismantling work. ▸ Wear work gloves.
	<p>⚠ WARNING</p> <p>Pump set tipping over or rolling off Risk of personal injury!</p> <ul style="list-style-type: none"> ▸ Make sure the pump set is secured against tipping over during the entire dismantling process. ▸ For dismantling the pump set in a horizontal position, secure it against rolling off.

Observe the general safety instructions and information.

For dismantling and reassembly observe the general assembly drawing.
In the event of damage you can always contact our service staff.

7.5.2 Preparing the pump set

1. De-energise the pump set and secure it against unintentional start-up.
2. The pump set has been removed from the discharge tube. (⇒ Section 7.3.1 Page 46)
3. The pump set has been cleaned. (⇒ Section 7.3.2 Page 47)
4. The lubricant has been drained.

7.5.3 Removing the back pull-out unit

- ✓ Suitable lifting equipment is provided.
1. Attach the eye hook to bail 571 to secure the back-pull out unit.
 2. Undo screwed connection 902.01 and 920.01. Attach lifting gear to bail 571 and pull the complete back pull-out unit out of pump casing 101 with a crane.
 3. Place the back pull-out unit in a safe and dry installation area and secure it against tipping over or rolling off.

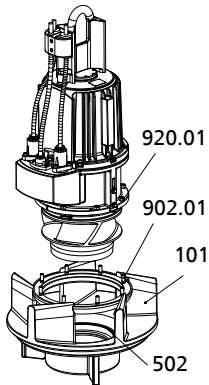

Fig. 27: Removing the back pull-out unit

7.5.4 Removing the impeller

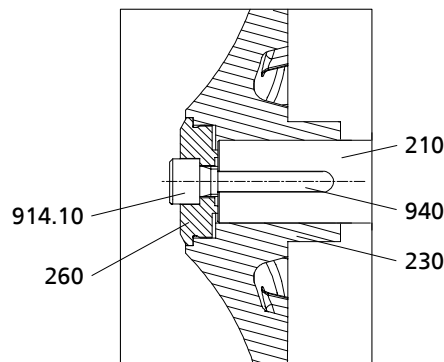

Fig. 28: Removing the impeller

- ✓ The back pull-out unit has been placed on wooden supports in horizontal position and is protected against rolling off.
 - ✓ The lubricant and leakage have been drained.
1. Unscrew socket head cap screw 914.10. **Note: right-hand thread**
 2. Unscrew impeller hub cap 260.
 3. Pull off impeller 230 with a special impeller removal tool.

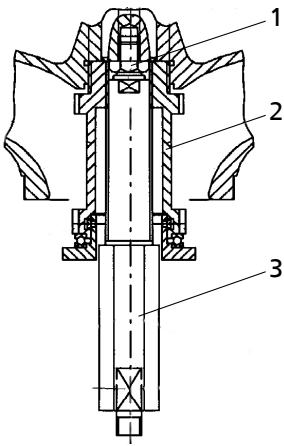

Fig. 29: Impeller removal tool

7.5.4.1 Using the special impeller removal tool

1. Screw hexagon head bolt 1 into the shaft end to prevent any damage to the shaft thread.
2. Screw part 2 into the impeller.
3. Screw fully threaded stud 3 into part 2 and pull off the impeller.
4. Remove keys 940.02 from shaft 210.



NOTE

The impeller removal device is not included in the scope of supply. It can be ordered separately from KSB.

Table 16: Special impeller removal tool

Size	Impeller type	Impeller removal tool
700 - 324	K	AV 1
700 - 330		
700 - 371		
800 - 330		
800 - 370		
800 - 400		
800 - 401		

7.5.5 Removing the mechanical seal

7.5.5.1 Removing the impeller-end mechanical seal

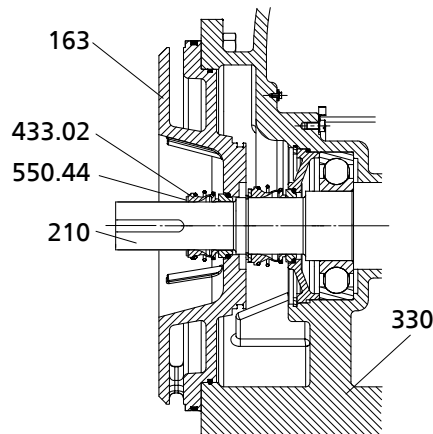

Fig. 30: Removing the mechanical seal

- ✓ The back pull-out unit has been securely placed in horizontal position on wooden supports.
1. Pull the rotating assembly of mechanical seal 433.02 and disc 550.44 off shaft 210.
 2. Remove discharge cover 163 from bearing bracket 330.

3. Press the stationary seat of mechanical seal 433.02 out of discharge cover 163.

7.5.5.2 Removing the drive-end mechanical seal

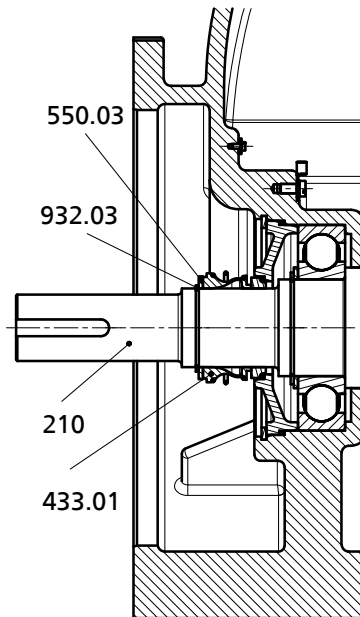

Fig. 31: Removing the mechanical seal

✓ The impeller and the impeller-end mechanical seal have been removed.

1. Remove circlip 932.03 and disc 550.03.
2. Carefully pull mechanical seal 433.01 and the mating ring of the mechanical seal off shaft 210.

	NOTE
<p>To protect the mechanical seal against damage when pulling it off the shaft it is recommended to place a foil (no thicker than 0.3 mm) around the free shaft stub.</p>	

7.5.6 Dismantling the motor section

	NOTE
<p>Special regulations apply to repair work on explosion-proof pump sets. Modifications or alteration of the pump set may affect explosion protection and are only permitted after consultation with the manufacturer.</p>	

	NOTE
<p>The motors of explosion-proof pump sets are supplied in "flameproof enclosure" type of protection. Any work on the motor part which may affect explosion protection, such as re-winding and machining repairs, must be inspected and approved by an approved expert or performed by the motor manufacturers. No modifications must be made to the internal configuration of the motor space. Repair work at the flameproof joints must only be performed in accordance with the manufacturer's instructions. Repair to the values in tables 1 and 2 of EN 60079-1 is not permitted.</p>	

When dismantling the motor section and the power cable make sure that the cores/terminals are clearly marked for future reassembly.

7.6 Reassembling the pump set

7.6.1 General information/Safety regulations

	<p>⚠ DANGER</p> <p>Wrong screws/bolts Explosion hazard!</p> <ul style="list-style-type: none"> ▶ Always use the original screws/bolts for assembling an explosion-proof pump set. ▶ Never use screws/bolts of different dimensions or of a lower property class.
	<p>⚠ WARNING</p> <p>Improper lifting/moving of heavy assemblies or components Personal injury and damage to property!</p> <ul style="list-style-type: none"> ▶ Use suitable transport devices, lifting equipment and lifting tackle to move heavy assemblies or components.
	<p>⚠ WARNING</p> <p>Components with sharp edges Risk of cutting or shearing injuries!</p> <ul style="list-style-type: none"> ▶ Always use appropriate caution for installation and dismantling work. ▶ Wear work gloves.
	<p>⚠ WARNING</p> <p>Insufficient stability Risk of crushing hands and feet!</p> <ul style="list-style-type: none"> ▶ During assembly/dismantling, secure the pump (set)/pump parts to prevent tipping or falling over.
	<p>CAUTION</p> <p>Improper reassembly Damage to the pump!</p> <ul style="list-style-type: none"> ▶ Reassemble the pump (set) in accordance with the general rules of sound engineering practice. ▶ Use original spare parts only.
	<p>NOTE</p> <p>Before reassembling the motor section, check that all joints relevant to explosion protection (flamepaths) are undamaged. Any components with damaged flamepaths must be replaced. Only use original spare parts made by KSB for explosion-proof pumps. Observe the flamepath positions specified in the Annex. Secure all screwed/bolted connections closing off the flameproof enclosure with a thread-locking agent (Loctite type 243).</p>
	<p>NOTE</p> <p>Apply liquid sealant to all screw plugs. Apply liquid sealant to all wetted clearances (e.g. Hylomar SQ 32M).</p>

Sequence Always reassemble the pump set in accordance with the corresponding general assembly drawing.

Sealing elements



- O-rings
 - Check O-rings for any damage and replace by new O-rings, if required.

- Never use O-rings that have been made by cutting an O-ring cord to size and gluing the ends together.
- Assembly adhesives
 - Avoid the use of assembly adhesives, if possible.

Tightening torques

For reassembly, tighten all screws and bolts as specified in this manual. (⇒ Section 7.8 Page 59)
 In addition, secure all screwed connections closing off the flameproof enclosure with a thread-locking agent (Loctite Type 243).

7.6.2 Reassembling the motor section

	NOTE
	<p>Before reassembling the motor section, check that all joints relevant to explosion protection (flamepaths) are undamaged. Any components with damaged flamepaths must be replaced. Only use original spare parts made by KSB for explosion-proof pumps. Observe the flamepath positions specified in the Annex. Secure all screwed/bolted connections closing off the flameproof enclosure with a thread-locking agent (Loctite type 243).</p>
	⚠ DANGER
	<p>Wrong screws/bolts Explosion hazard!</p> <ul style="list-style-type: none"> ▷ Always use the original screws/bolts for assembling an explosion-proof pump set. ▷ Never use screws/bolts of different dimensions or of a lower property class.

7.6.3 Installing the mechanical seals

Observe the following to ensure trouble-free operation of the mechanical seal:

- Only remove the protective wrapping of the contact faces immediately before assembly takes place.
- The shaft surface must be absolutely clean and undamaged.
- Immediately before installing the mechanical seal, wet the contact faces with a drop of oil.
- For easier installation of bellows-type mechanical seals, wet the inside diameter of the bellows with soapy water (not oil).
- To prevent any damage to the rubber bellows, place a thin foil (of approximately 0.1 to 0.3 mm thickness) around the free shaft stub. Slide the rotating assembly over the foil into its installation position. Then remove the foil.

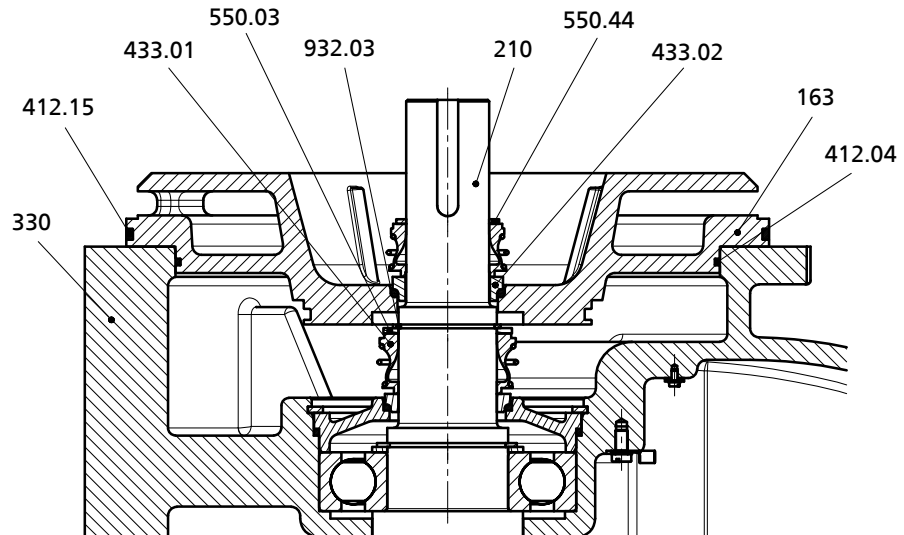
Fig. 32: Fitting the mechanical seals

- ✓ The shaft and rolling element bearings have been properly fitted in the motor.
- 1. Guide drive-end mechanical seal 433.01 with disc 550.03 on shaft 210 and secure it with circlip 932.03.
- 2. Insert O-rings 412.04 and 412.15 into discharge cover 163, and press them into bearing bracket 330 as far as they will go.
- 3. Slip impeller-end mechanical seal 433.02 and disc 550.44 onto shaft 210.

For special mechanical seals with covered springs, tighten the socket head cap screw at the rotating assembly before fitting the impeller. Observe installation dimension "A".

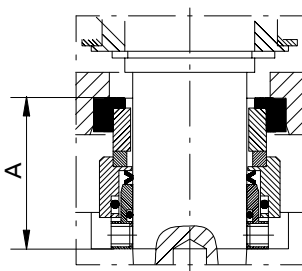
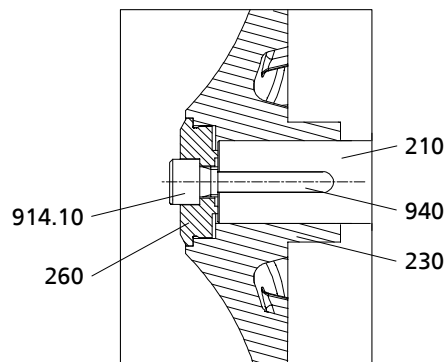

Fig. 33: Installation dimension "A"

Table 17: Installation dimension "A"

Size	Installation dimension "A"
	[mm]
700 - 324	48,3
700 - 330	
700 - 371	
800 - 330	
800 - 370	
800 - 400	
800 - 401	

7.6.4 Fitting the impeller

The impeller is reassembled with the help of an impeller fitting tool.

Fig. 34: Fitting the impeller

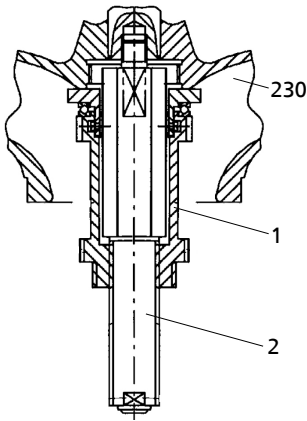
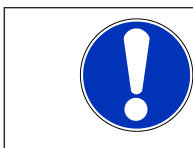

Fig. 35: Special impeller fitting tool

- ✓ The mechanical seals have been properly installed.
- 1. Insert key 940 into shaft 210.
- 2. Screw part 2 of the impeller fitting tool into the shaft end of the pump set.
- 3. Screw part 1 to the threaded bolt part 2.
- 4. Insert impeller hub cap 260 and fasten it with socket head cap screw 914.10.

7.6.5 Installing the back pull-out unit



NOTE

After casing wear rings with a radial clearance have been fitted in pump casing 101 they have the required inner diameter and do not need to be readjusted.

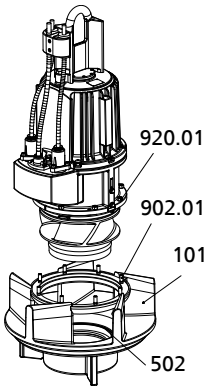

Fig. 36: Installing the back pull-out unit

1. Use a rubber mallet to tap casing wear ring 502 into pump casing 101 as far as it will go.
2. Insert the complete back pull-out unit into pump casing 101.
3. Evenly tighten screwed connection 920.01 between pump casing and bearing bracket.

7.6.6 Leak testing

After reassembly, the mechanical seal area/lubricant reservoir must be checked for leakage. The leak test is performed at the lubricant filler opening.

Observe the following values for leak testing:

- **Test medium:** compressed air
- **Test pressure:** 0.8 bar maximum
- **Test duration:** 2 minutes

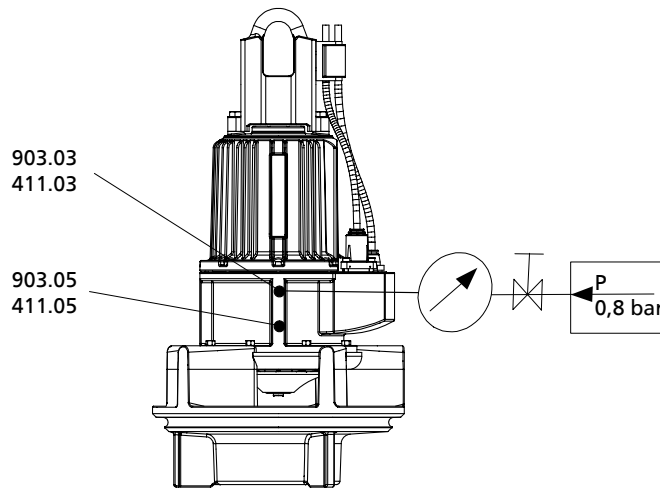

Fig. 37: Screwing in the testing device

1. Undo and remove screw plug 903.03 and joint ring 411.03 of the lubricant reservoir.
2. Screw the testing device tightly into the lubricant filler opening.
3. Carry out the leak test with the values specified above.
The pressure must not drop during the test period.
If the pressure does drop, check the seals and screwed connections.
Then perform another leak test.
4. If the leak test has been successful, fill in the lubricant.
5. Screw in screw plug 903.03 and joint ring 411.03 of the lubricant reservoir.

7.7 Checking the connection of motor/power supply

Once reassembly has been completed, carry out the steps described in (⇒ Section 7.2.1 Page 44) .

7.8 Tightening torques

Table 18: Bolt tightening torques [Nm] depending on thread, steel grade and property class

Steel grade	Tightening torque M_A [Nm]									
	8.8		A2, A4		A2, A4		1.4410		1.4462	
	Minimum	Rated torque	Minimum	Rated torque	Minimum	Rated torque	Minimum	Rated torque	Minimum	Rated torque
Property class	8.8		-50		-70		$R_{p0.2} \geq 530 \text{ N/mm}^2$		$R_{p0.2} \geq 450 \text{ N/mm}^2$	
Thread	Minimum	Rated torque	Minimum	Rated torque	Minimum	Rated torque	Minimum	Rated torque	Minimum	Rated torque
M4	3,0	3,4	1,0	1,1	2,1	2,4	2,5	2,8	2,1	2,4
M5	6,1	6,8	2,0	2,2	4,3	4,8	5,0	5,6	4,3	4,8
M6	10,3	11	3,4	3,7	7,2	8,0	8,5	9,5	7,2	8,0
M8	25	28	8,2	9,1	18	19	21	23	18	19
M10	49	55	16	18	35	38	41	45	35	38
M12	85	94	28	31	59	66	70	78	59	66
M14	134	149	44	49	94	105	111	124	94	105
M16	209	232	69	76	147	163	173	192	147	163
M20	408	453	134	149	287	319	338	375	287	319
M24	704	782	231	257	495	550	583	648	495	550
M27	1025	1139	36	374	721	801	849	944	721	801
M30	1403	1559	460	511	986	1096	1162	1291	986	1096
M33	1888	2098	619	688	1327	1475	1563	1737	1327	1475
M36	2445	2717	802	891	1719	1910	2025	2250	1719	1910
M42	3904	4338	1281	1423	2745	3050	3233	3592	2745	3050
M48	5880	6534	1929	2144	4135	4594	4870	5411	4135	4594



NOTE

If using an adjustable torque wrench or screwdriver, adjust it to a value within the indicated range between the minimum and the rated torque.

7.9 Spare parts stock

7.9.1 Ordering spare parts

Always quote the following data when ordering replacement or spare parts:

- Order number
- Order item number
- Type series
- Size
- Year of construction
- Motor number

Refer to the name plate for all data. (⇒ Section 4.3 Page 16)

Also specify the following data:

- Part number and description
- Quantity of spare parts
- Shipping address
- Mode of dispatch (freight, mail, express freight, air freight)

7.9.2 Recommended spare parts stock for 2 years' operation to DIN 24296

Table 19: Quantity of spare parts for recommended spare parts stock²⁾

Part No.	Description	Number of pump sets (including stand-by pump sets)						
		2	3	4	5	6 and 7	8 and 9	10 and more
80-1	Motor unit	-	-	-	1	1	2	30 %
834	Cable gland	1	1	2	2	2	3	40 %
818	Rotor	-	-	-	1	1	2	30 %
230	Impeller	1	1	1	2	2	3	30 %
502	Casing wear ring	2	2	2	3	3	4	50 %
433.01	Mechanical seal, motor end	2	3	4	5	6	7	90 %
433.02	Mechanical seal, pump end	2	3	4	5	6	7	90 %
322	Rolling element bearing, motor end	1	1	2	2	3	4	50 %
321.02	Rolling element bearing, pump end	1	1	2	2	3	4	50 %
99-9	Set of sealing elements for the motor	4	6	8	8	9	10	100 %
99-9	Set of sealing elements for the hydraulic system	4	6	8	8	9	10	100 %
412.20	O-ring for sealing the discharge tube	2	3	4	5	6	8	100 %

²⁾ For two years of continuous operation or 17,800 operating hours

8 Trouble-shooting

	⚠ WARNING
	<p>Improper work to remedy faults Risk of injury!</p> <p>▸ For any work to remedy faults observe the relevant information in this manual or in the relevant accessory manufacturer's product literature.</p>

If problems occur that are not described in the following table, consultation with the KSB customer service is required.

- A Pump is running but does not deliver
- B Pump delivers insufficient flow rate
- C Excessive current/power consumption
- D Insufficient discharge head
- E Vibrations and noise during pump operation

Table 20: Trouble-shooting

A	B	C	D	E	Possible causes	Remedy ³⁾
-	X	-	-	X	Water level lowered too much during operation	Check supply and capacity of system (sump floor area). Check level control equipment.
X	X	-	-	X	Total pressure corresponding to $NPSH_{pump}$ too high Total pressure corresponding to $NPSH_{system}$ too low	Increase fluid level on the suction side. Clean screening equipment, if required.
X	X	X	-	X	Penetration of air into the pump due to formation of an air pocket - Suction-side water level too low	Increase the suction-side water level. If this is not possible or unsuccessful, please contact KSB.
X	X	X	-	X	Unfavourable flow to the pump inlet	Improve the flow to the intake chamber (contact KSB).
-	X	X	-	X	Pump running in off-design conditions - low flow/overload	Check the pump's operating data.
X	X	-	X	X	Pump clogged by deposits	Clean intake and pump components.
-	X	X	X	X	Wear	Replace worn parts.
-	X	-	X	X	Impermissible air or gas content in the fluid handled	Contact KSB.
-	-	-	-	X	System-induced vibrations	Contact KSB.
-	-	X	-	X	Wrong direction of rotation	Check the electrical connection of motor and control system, if any.
X	-	-	-	-	No voltage	Check electrical connections. Contact the energy supplier.
X	-	-	-	-	Motor winding or electric cable are defective.	Replace with original KSB cable or contact KSB.
-	-	X	-	X	Worn or defective rolling element bearings	Contact KSB.
X	-	-	-	-	The thermistor tripping unit with manual reset for temperature limiter has tripped the pump as a result of the permissible winding temperature being exceeded.	Have cause determined and eliminated by qualified and trained personnel.
X	-	-	-	-	Motor has been tripped by leakage monitor.	Have cause determined and eliminated by qualified and trained personnel.
X	-	-	-	-	Mechanical seal monitor has tripped.	Have cause determined and eliminated by qualified and trained personnel.
X	-	-	-	-	Bearing temperature monitor has tripped.	Have cause determined and eliminated by qualified and trained personnel.
-	X	-	X	-	In case of star-delta configuration: motor running in star configuration only	Check star-delta contactor.

³⁾ The pump pressure must be released before attempting to remedy faults on parts which are subjected to pressure. Disconnect the pump set from the power supply!

9 Related Documents

9.1 General assembly drawing

9.1.1 General assembly drawing

This general assembly drawing applies to the following hydraulic system and motor sizes:

Hydraulic system size:

Amacan K 700 - 324; Amacan K 700 - 330
 Amacan K 700 - 371; Amacan K 800 - 370
 Amacan K 800 - 400; Amacan K 800 - 401

Motor sizes:

29 4
 20 6, 26 6
 10 8, 17 8, 21 8

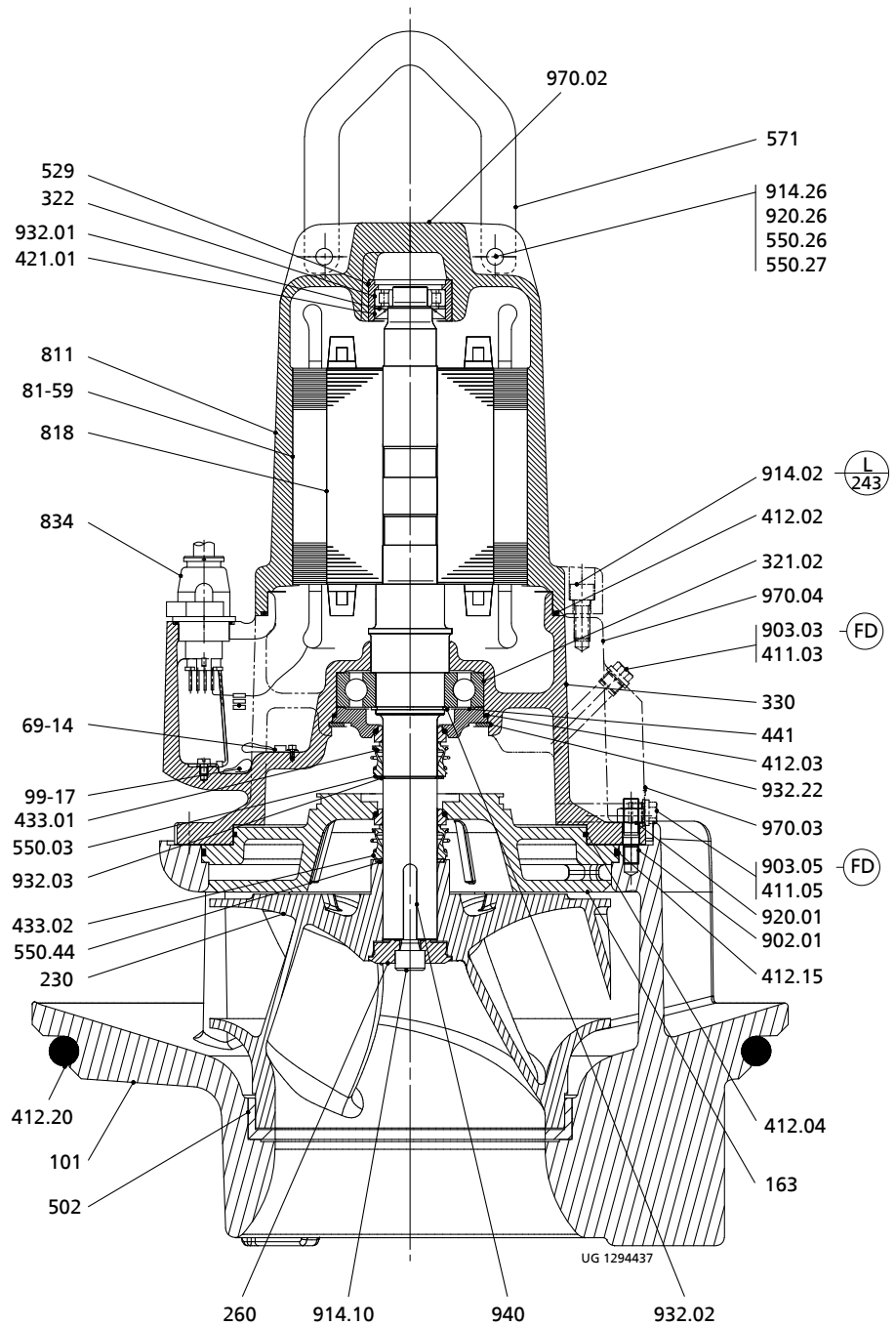

Fig. 38: General assembly drawing

Table 21: Detailed views of the general assembly drawing

Description	Details
Cable gland (standard version)	
Cable gland (power and control cables)	

Table 22: List of components

Part No.	Description	Part No.	Description
101	Pump casing	596	Wire
163	Discharge cover	69-14	Leakage monitor
230	Impeller	81-51	Clamping element
260	Impeller hub cap	81-59	Stator
321.02	Radial ball bearing	811	Motor housing
322	Radial roller bearing	818	Rotor
330	Bearing bracket	834.01/03	Cable gland
411.03/05	Joint ring	99-17	Desiccant
412.02/03/04/07/08/15/20	O-ring	902.01	Stud
421.01	Lip seal	903.03/05	Screw plug
433.01/02	Mechanical seal	914.02/04/05/10/26	Hexagon socket head cap screw
441	Shaft seal housing	920.01/26	Nut
502	Casing wear ring	932.01/02/03/22	Circlip
529	Bearing sleeve	940	Key
550.03/26/27/44	Disc	970.02/03/04	Label/plate
571	Bail		

Table 23: Key to the symbols and codes

Symbol	Description
	Always secure screwed connections marked with this symbol with Loctite 243 .
	Always apply a liquid sealing agent (e.g. Hylomar SQ32M) to sealing surfaces marked with this symbol.

9.1.2 General assembly drawing

This general assembly drawing applies to the following hydraulic system and motor sizes:

Hydraulic system sizes:

- Amacan K 800 - 330
- Amacan K 800 - 370
- Amacan K 800 - 400
- Amacan K 800 - 401

Motor sizes:

- 35 4, 50 4, 65 4
- 32 6, 40 6, 50 6
- 26 8, 35 8

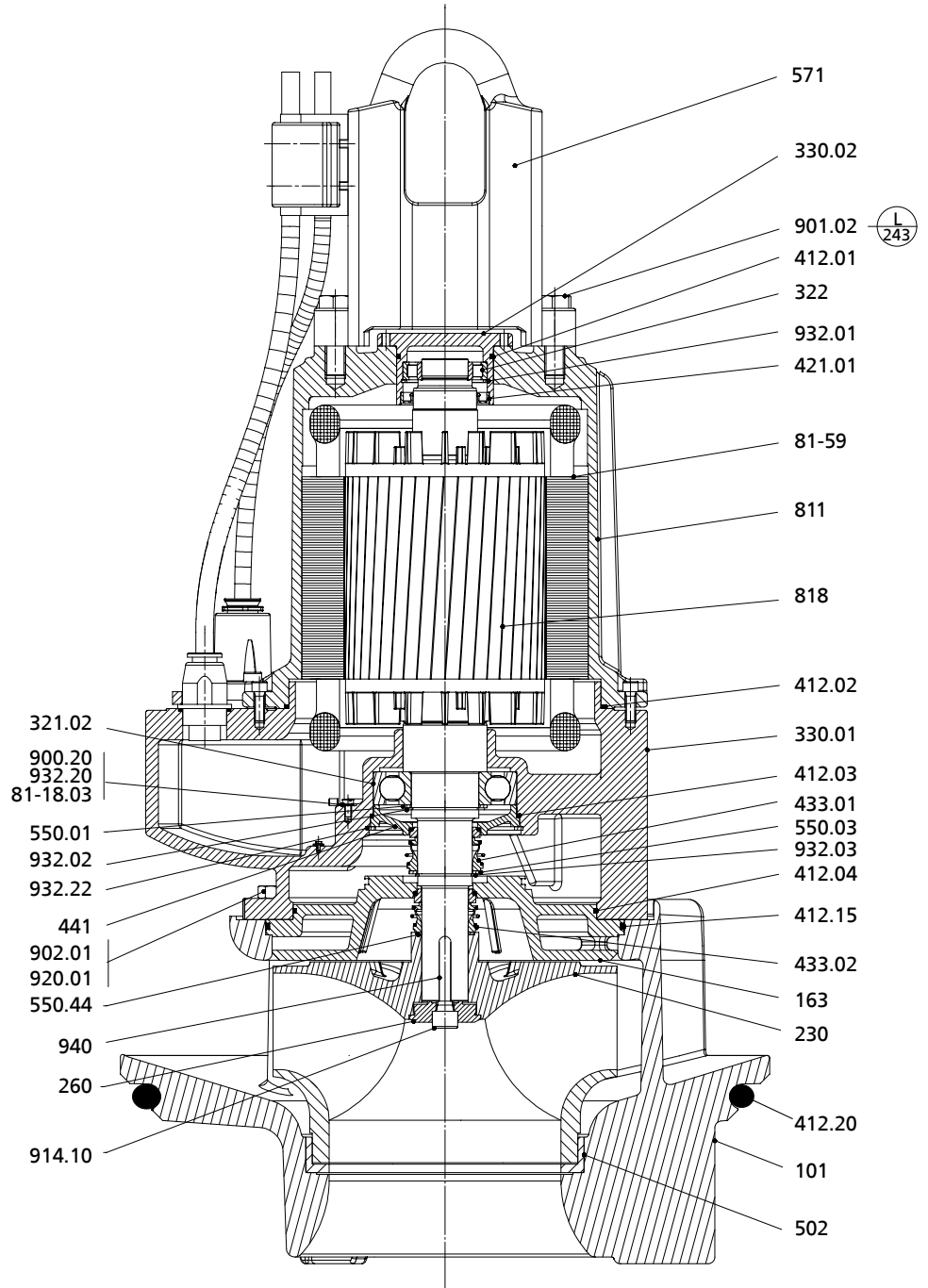

Fig. 39: General assembly drawing



Table 24: Detailed views of the general assembly drawing

Description	Details
Cable gland	<p>Exploded view of a cable gland assembly. Callouts include: 914.05 (top left), 81-51 (top left), 834.03 (top left), 412.08 (top left), 914.04 (bottom left), 834.01 (bottom left), 412.07 (bottom left), 970.02 (bottom center), 914.01 (bottom right), and 914.02 (top right). Circled 'L' symbols with '243' are present near callouts 914.05, 914.04, and 914.01.</p>
Bearing temperature sensor	<p>Cross-section of a bearing temperature sensor assembly. Callouts include: 69-6.01* (top), 520.01* (middle), and 69-14 (bottom left). A note below the diagram states: * = optional</p>
Bracket	<p>3D perspective view of a bracket assembly. Callouts include: 571 (top), 81-97.01 (middle left), 81-97.02 (middle left), 82-11 (middle left), and 914.25 (middle left).</p>

Table 25: List of components

Part No.	Description	Part No.	Description
101	Pump casing	81-18.03	Cable terminal
163	Discharge cover	81-51	Clamping element
230	Impeller	81-59	Stator
260	Impeller hub cap	81-97.01/.02	Cable protector
321.02	Radial ball bearing	811	Motor housing
322	Radial roller bearing	818	Rotor
330.01/.02	Bearing bracket	82-11	Strain relief device
412.01/.02/.03/.04/.07/.08/.15/.20	O-ring	834.01/.03	Cable gland
421.01	Lip seal	900.20	Screw
433.01/.02	Mechanical seal	901.02	Hexagon head bolt
441	Shaft seal housing	902.01	Stud
502	Casing wear ring	914.01/.02/.04/.05/.10/.25	Hexagon socket head cap screw
520.01	Sleeve	920.01	Nut
550.01/.03/.44	Disc	932.01/.02/.03/.20/.22	Circlip
571	Bail	940	Key
69-6.01	Temperature sensor	970.02	Label/plate
69-14	Leakage monitor		

Table 26: Key to the symbols and codes

Symbol	Description
	Always secure screwed connections marked with this symbol with Loctite 243 .
	Always apply a liquid sealing agent (e.g. Hylomar SQ32M) to sealing surfaces marked with this symbol.

9.2 Sectional drawings of the mechanical seal

The sectional drawings apply to the following pump sizes:

Hydraulic system sizes:
 Amacan K 700 - 324
 Amacan K 700/800 - 330
 Amacan K 700 - 371
 Amacan K 800 - 370
 Amacan K 800 - 400
 Amacan K 800 - 401

Motor sizes:
 29 4, 35 4, 50 4, 65 4
 20 6, 26 6, 32 6, 40 6, 50 6
 10 8, 17 8, 21 8, 26 8, 35 8

Table 27: Sectional drawings of the mechanical seal

Description	Details
Bellows-type mechanical seal	
Mechanical seal with covered springs	 <p data-bbox="526 1646 670 1668">A = 48.3 mm</p>

Table 28: List of components

Part No.	Description	Part No.	Description
433.01/02	Mechanical seal	932.03	Circlip
550.03/44	Disc		

9.3 Cable bundle

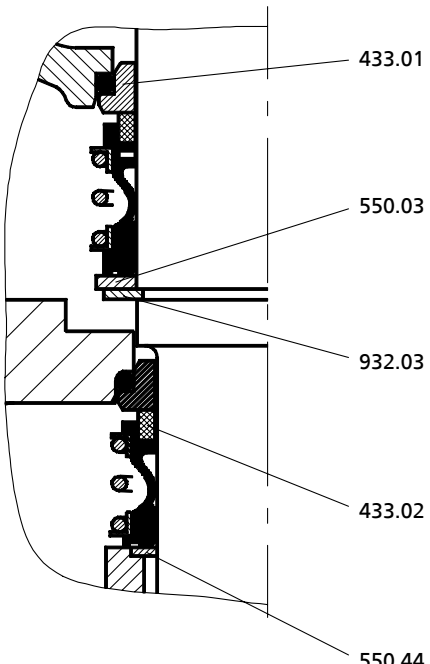
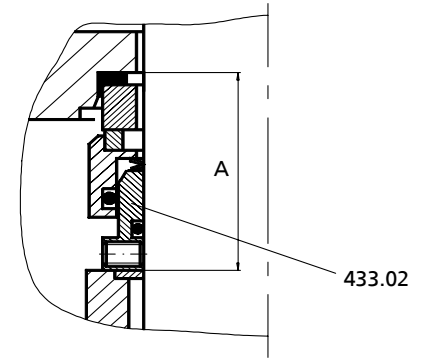
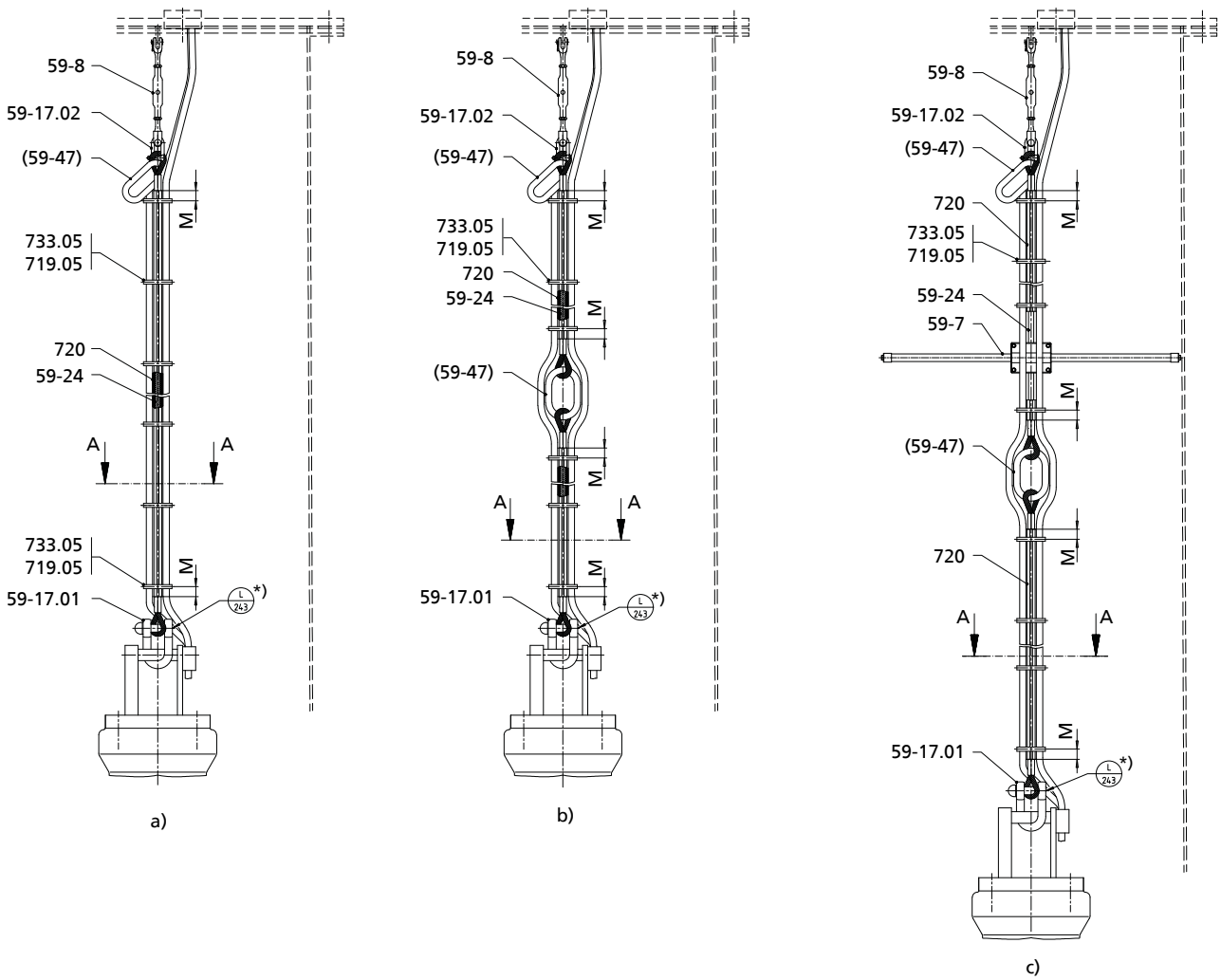

Fig. 40: Cable bundle: a) basic design b) with lifting lug c) with support
 *) Only required for galvanised version. (⇒ Section 5.3.3 Page 27)

	NOTE
	Distance M = 50 mm

Table 29: Key to the symbols and codes

Symbol	Description
	Always secure screwed connections marked with this symbol with Loctite 243 .

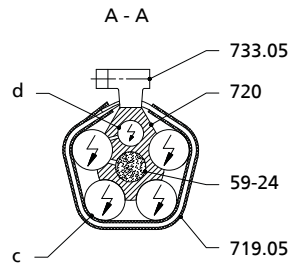

Fig. 41: Cross-section A - A, position of power cable, control cable and support rope

c	Power cable	d	Control cable
---	-------------	---	---------------

Table 30: List of components of the cable bundle

Part No.	Description	Part No.	Description
59-7	Support	59-47	Lifting lug
59-8	Turnbuckle	719.05	Flexible tube
59-17.01/02	Shackle	720	Fitting
59-24	Rope / support rope	733.05	Hose clip

9.4 Wiring diagrams

9.4.1 Wiring diagram, motor 29 4, 20 6, 26 6, 10 8, 17 8, 21 8

Electric cables
12G1.5
12G2.5

Electric cables
7G4 + 5x1.5
7G6 + 5x1.5
7G10 + 5x1.5

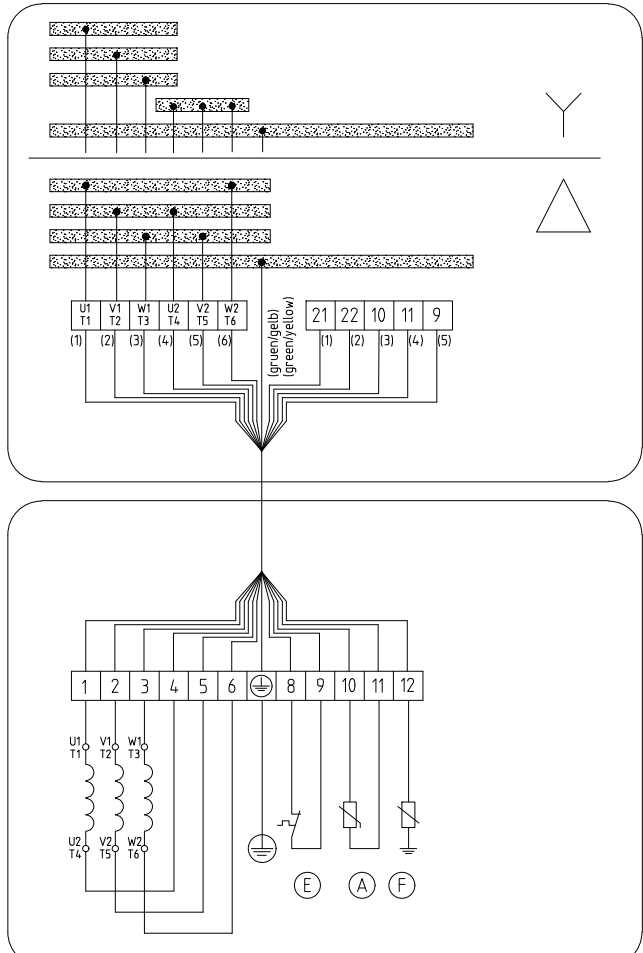
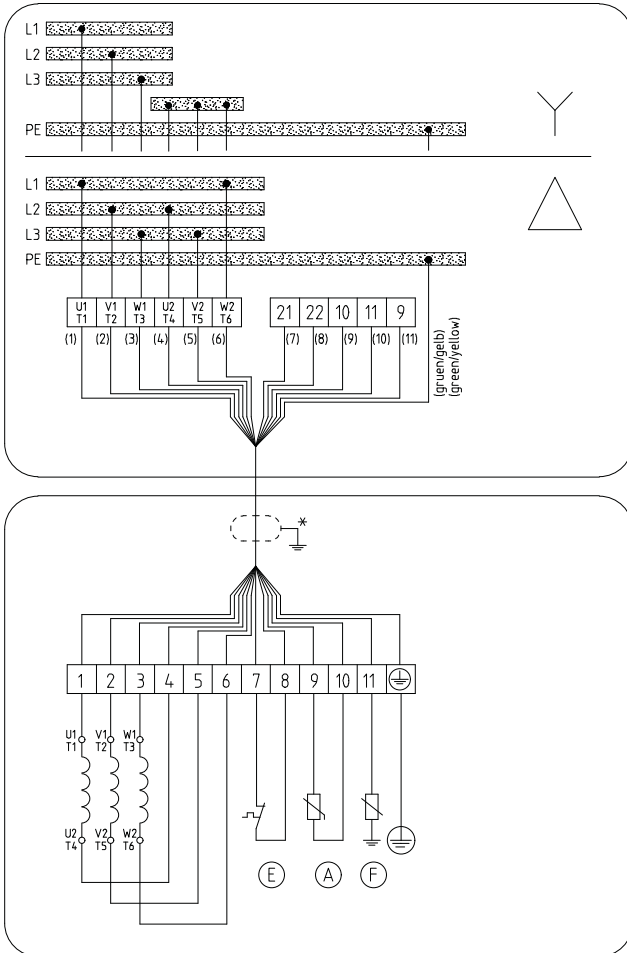

*	Shielded cables optional
Ⓐ	Motor temperature (PTC)
Ⓔ	Motor temperature
Ⓕ	Leakage inside the motor

9.4.2 Wiring diagram, motor 35 4, 50 4, 65 4, 32 6, 40 6, 50 6, 26 8

Standard pump set

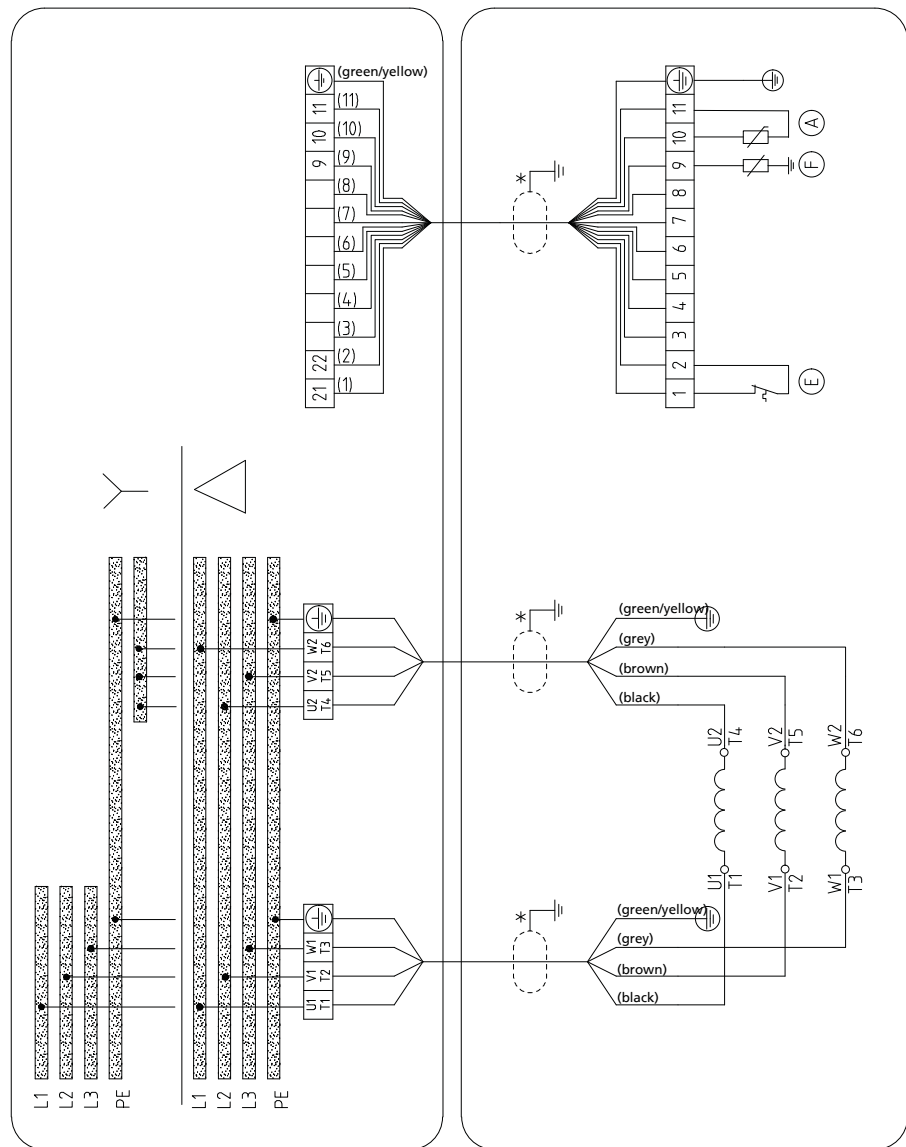

Fig. 42: Wiring diagram for standard pump sets

*	Shielded cables optional
(A)	Motor temperature (PTC)
(E)	Motor temperature
(F)	Leakage inside the motor

Pump sets
with additional bearing
temperature monitoring

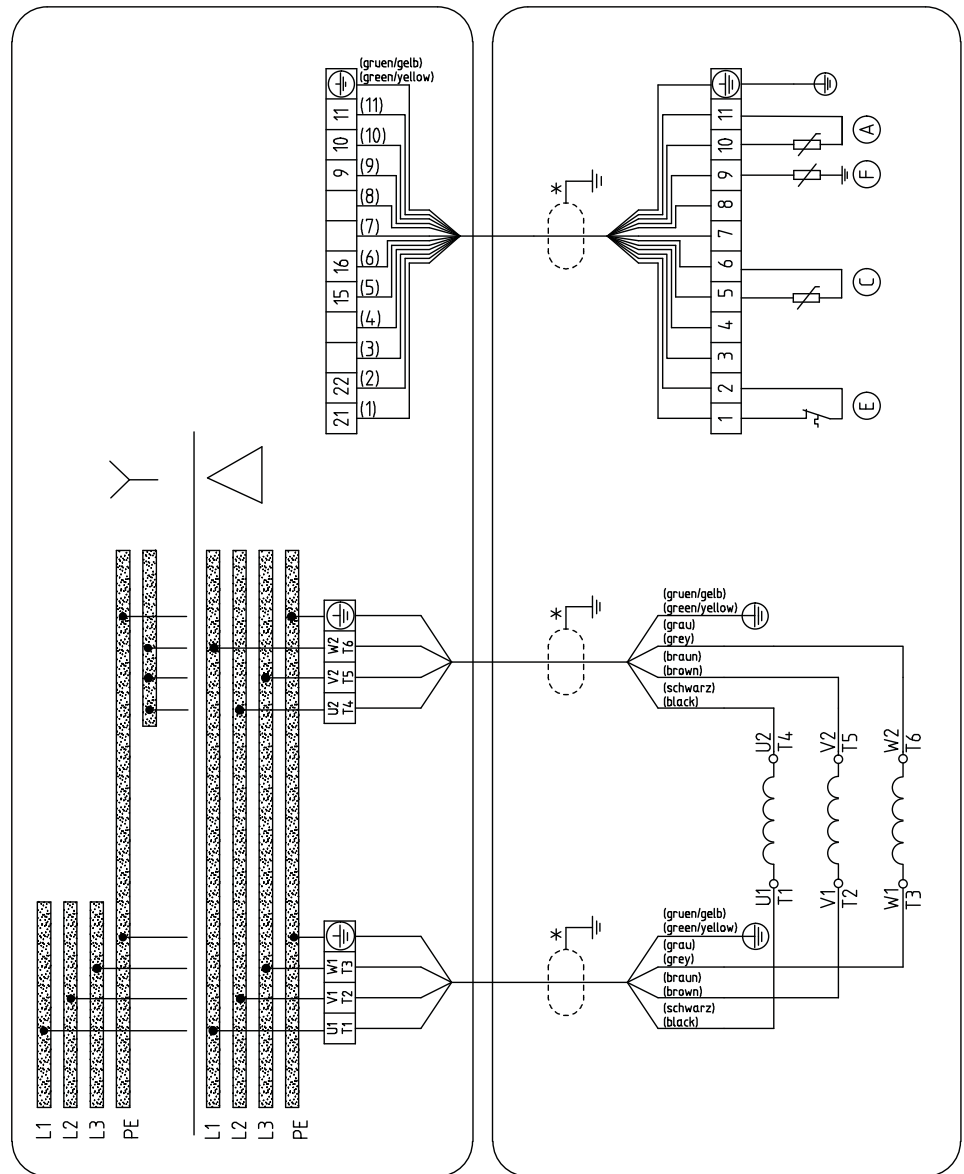

Fig. 43: Wiring diagram with additional bearing temperature monitoring

*	Shielded cables optional
(A)	Motor temperature (PTC)
(C)	Bearing temperature (lower bearings)
(E)	Motor temperature
(F)	Leakage inside the motor

9.5 Flamepaths on explosion-proof motors

9.5.1 Motor sizes: 29 4, 20 6 ... 26 6, 10 8 ... 17 8

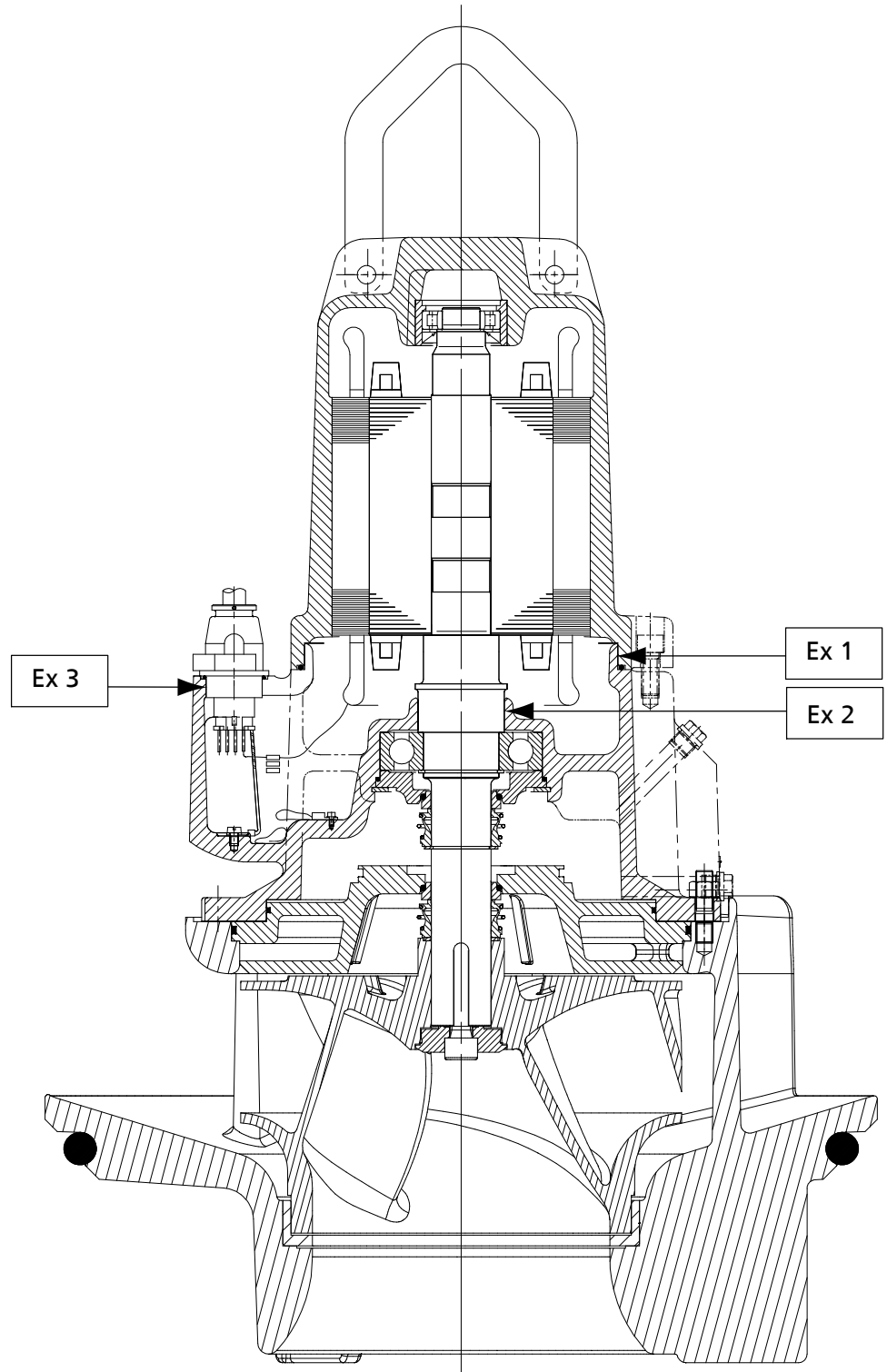

Fig. 44: Flamepaths

9.5.2 Motor sizes: 35 4 ...65 4, 32 6 ... 50 6, 26 8

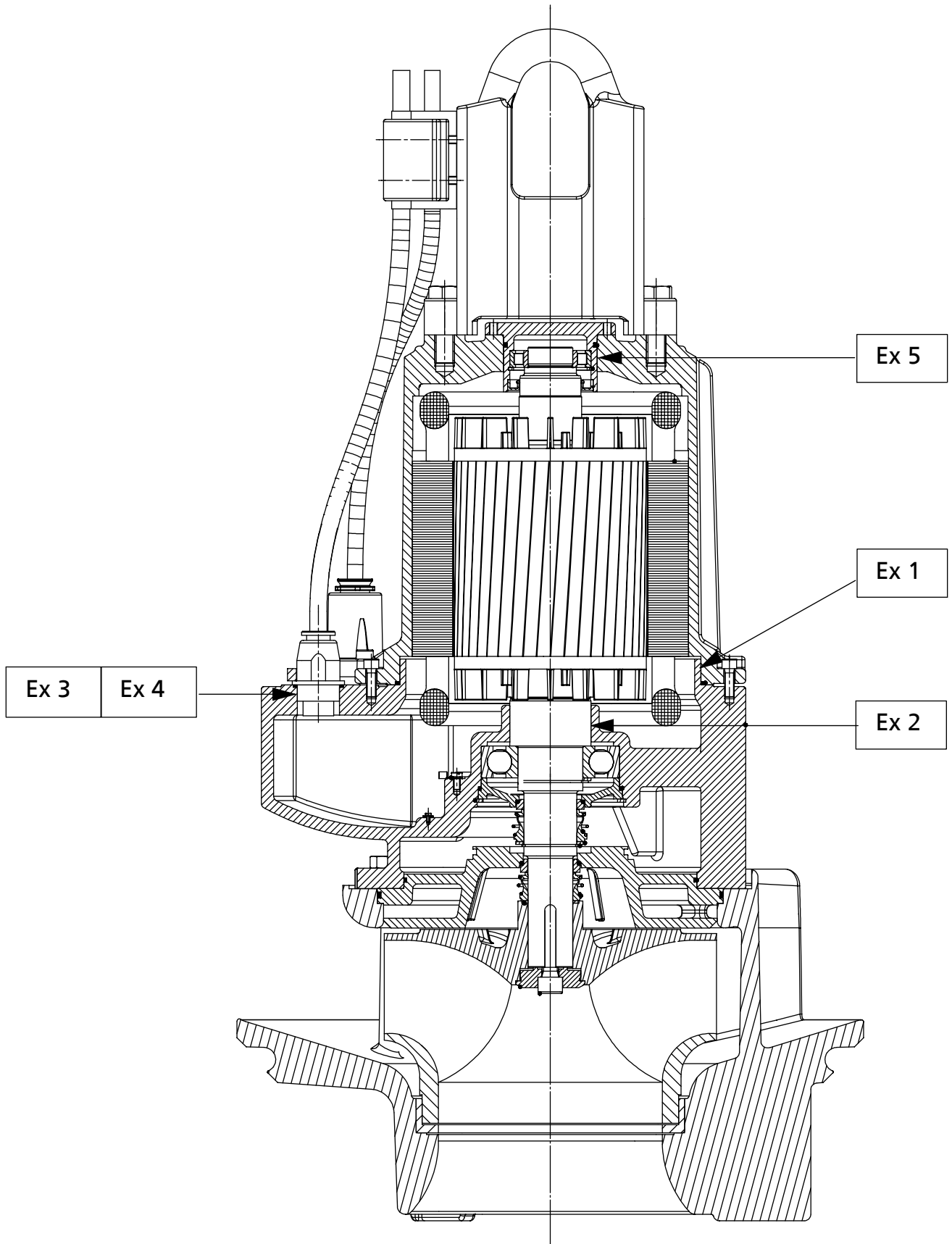

Fig. 45: Flamepaths

9.6 Dimensions

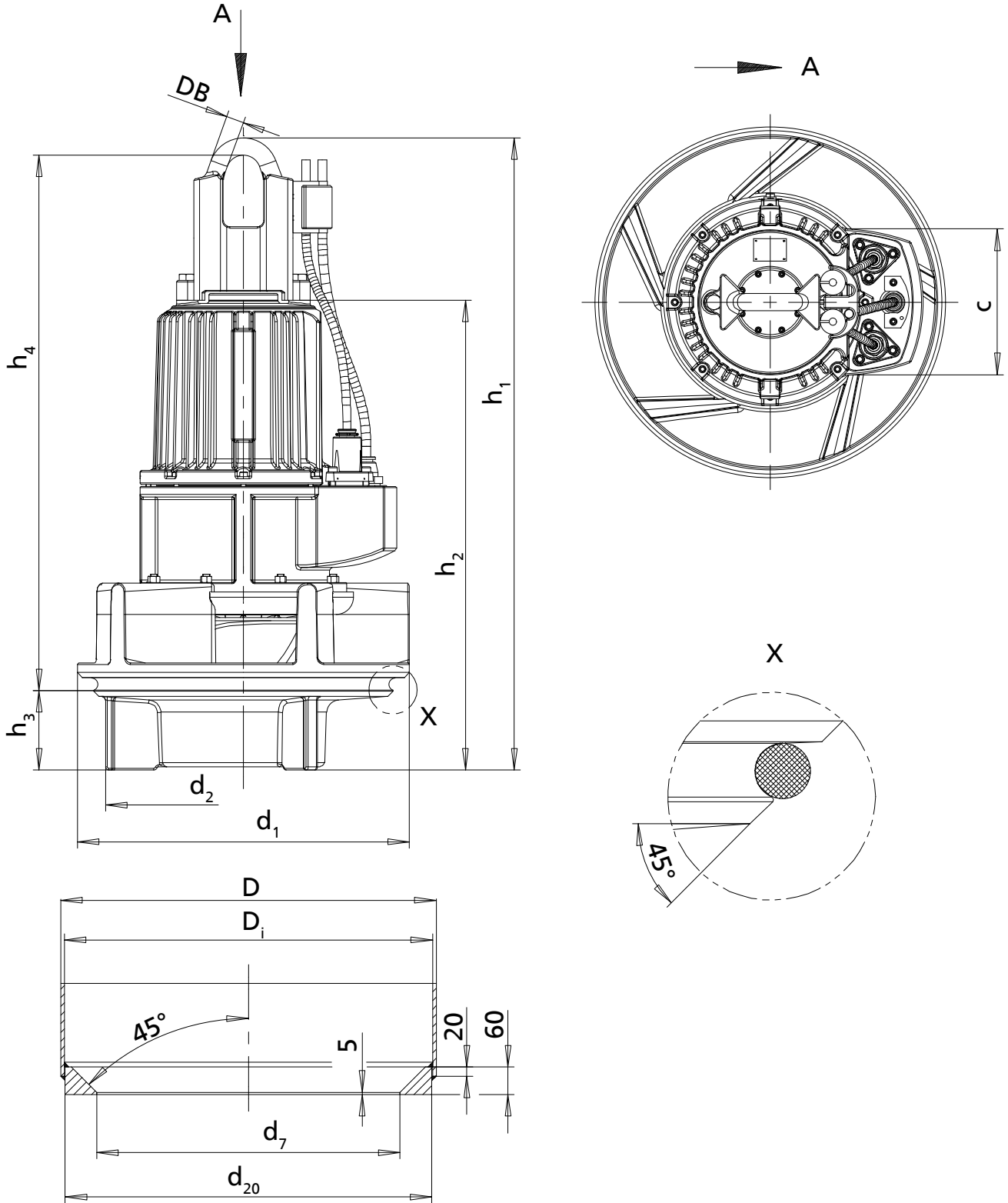

Fig. 46: Outline drawing

Table 31: Dimensions [mm]

Size	Motor size	No. of poles	Pump									Seating ring			
			h ₁	h ₂	h ₃	h ₄	DB	d ₁	d ₂	c	[kg] ⁴⁾	d ₇	d ₂₀	D _i	D ⁵⁾
700-324	20	6	1150	985	151	985	15	670	556	205	411	570	691	695	711
700-324	26	6	1125	960	151	960	15	670	556	205	433	570	691	695	711
700-324	10	8	1150	985	151	985	15	670	556	205	394	570	691	695	711
700-324	17	8	1150	985	151	985	15	670	556	205	410	570	691	695	711
700-330	29	4	1125	960	151	960	15	670	556	205	442	570	691	695	711
700-330	20	6	1150	985	151	985	15	670	556	205	418	570	691	695	711
700-330	26	6	1125	960	151	960	15	670	556	205	440	570	691	695	711
700-371	20	6	1150	985	151	985	15	670	556	205	414	570	691	695	711
700-371	26	6	1125	960	151	960	15	670	556	205	436	570	691	695	711
700-371	10	8	1150	985	151	985	15	670	556	205	397	570	691	695	711
800-330	35	4	1410	1035	151	1219	40	670	556	340	589	570	793	797	813
800-330	50	4	1410	1035	151	1219	40	670	556	340	613	570	793	797	813
800-330	65	4	1410	1035	151	1219	40	670	556	340	645	570	793	797	813
800-370	20	6	1105	945	148	945	15	760	640	205	444	656	793	797	813
800-370	26	6	1080	920	148	920	15	760	640	205	466	656	793	797	813
800-370	32	6	1370	995	148	1181	40	760	640	340	608	656	793	797	813
800-370	40	6	1370	995	148	1181	40	760	640	340	634	656	793	797	813
800-400	26	6	1175	1015	183	980	15	770	640	205	574	656	793	797	813
800-400	32	6	1465	1090	183	1241	40	770	640	340	716	656	793	797	813
800-400	40	6	1465	1090	183	1241	40	770	640	340	742	656	793	797	813
800-400	50	6	1465	1090	183	1241	40	770	640	340	771	656	793	797	813
800-400	10	8	1200	1040	183	1005	15	770	640	205	535	656	793	797	813
800-400	17	8	1200	1040	183	1005	15	770	640	205	551	656	793	797	813
800-400	21	8	1175	1015	183	980	15	770	640	205	573	656	793	797	813
800-400	26	8	1465	1090	183	1241	40	770	640	340	717	656	793	797	813
800-401	26	6	1175	1015	183	980	15	770	640	205	557	656	793	797	813
800-401	32	6	1465	1090	183	1241	40	770	640	340	699	656	793	797	813
800-401	40	6	1465	1090	183	1241	40	770	640	340	725	656	793	797	813
800-401	50	6	1465	1090	183	1241	40	770	640	340	754	656	793	797	813
800-401	10	8	1200	1040	183	1005	15	770	640	205	518	656	793	797	813
800-401	17	8	1200	1040	183	1005	15	770	640	205	534	656	793	797	813
800-401	21	8	1175	1015	183	980	15	770	640	205	556	656	793	797	813
800-401	26	8	1465	1090	183	1241	40	770	640	340	700	656	793	797	813

4) Pump set with 10-metre connection cable (400 V) and 5-metre support rope

5) D for recommended wall thickness of the discharge tube (see dimension s1 in the General Arrangement Drawings)

9.7 General arrangement drawings

9.7.1 Installation type BU

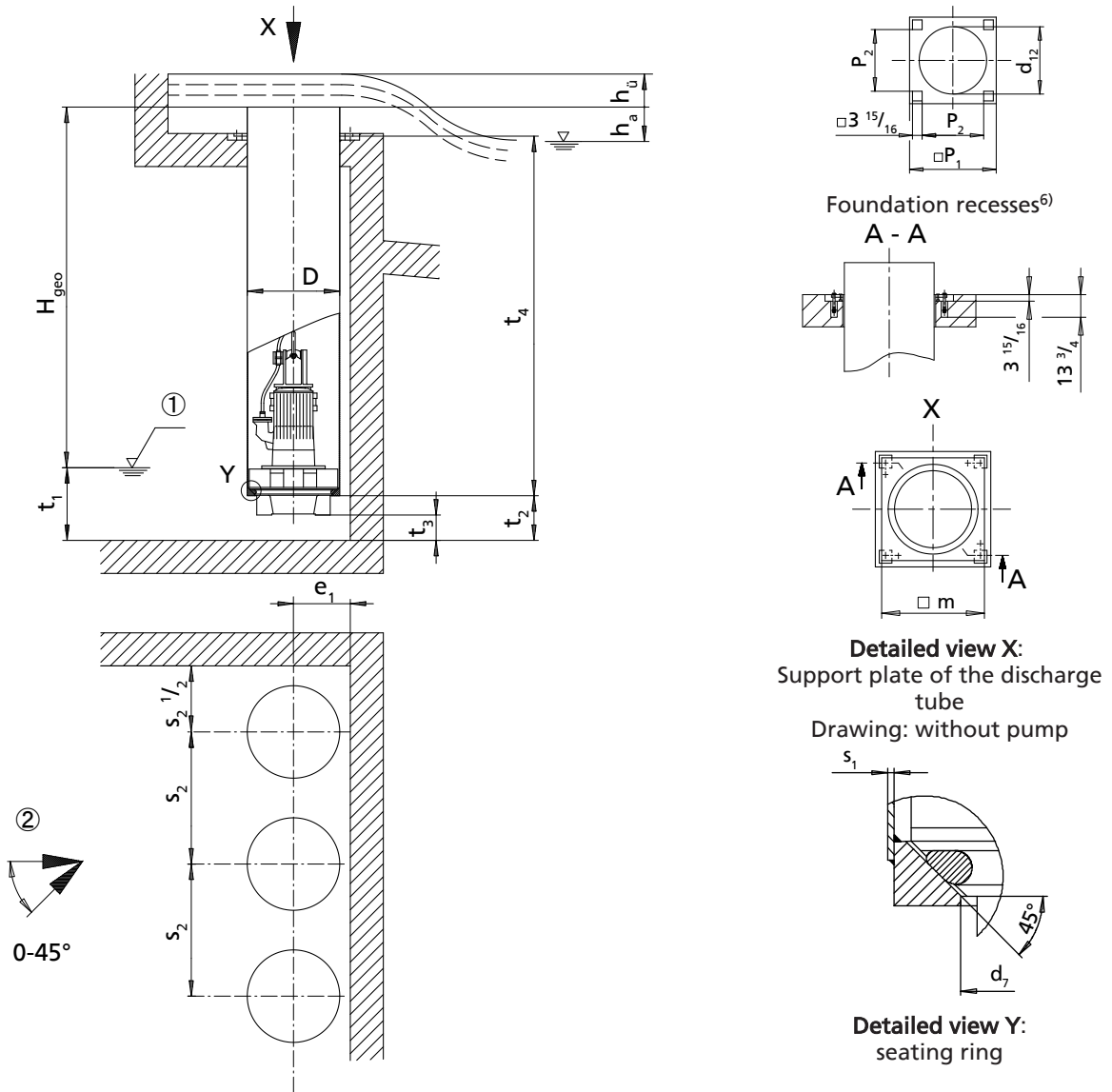

①: Minimum water level (see diagram on the following page)

②: Approach flow

Table 32: Dimensions [mm]

Size	D	d ₇	d ₁₂	e ₁ ⁷⁾	h _a	m	p ₁	p ₂	s _{1 min}	s _{2 min}	t ₂ ⁷⁾	t ₃	t _{4 min} ⁸⁾
700 - 324	711	570	750	430	100	800	900	640	8	1150	330	200	1200
700 - 330	711	570	750	430	100	800	900	640	8	1150	330	200	1200
700 - 371	711	570	750	430	100	800	900	640	8	1150	330	200	1200
800 - 330	813	570	850	480	100	910	1000	740	8	1150	330	200	1500
800 - 370	813	656	850	480	100	910	1000	740	8	1150	330	200	1400
800 - 400	813	656	850	480	100	910	1000	740	8	1400	410	250	1500
800 - 401	813	656	850	480	100	910	1000	740	8	1400	410	250	1500

6) All dimensions for foundation recesses apply to discharge tube design without intermediate flange.

7) Always observe this dimension.

8) Value for maximum motor length

Permissible tolerances:

- Tolerances in building construction to DIN 18202, Part 4, Group B
- Welded design: B/F to DIN EN ISO 13920
- Tolerances for conical seat (detailed view Y): ISO 2768-mH

Loss diagram

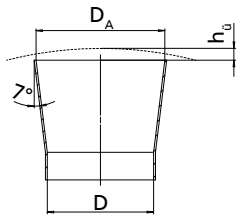

Overflow head h_u

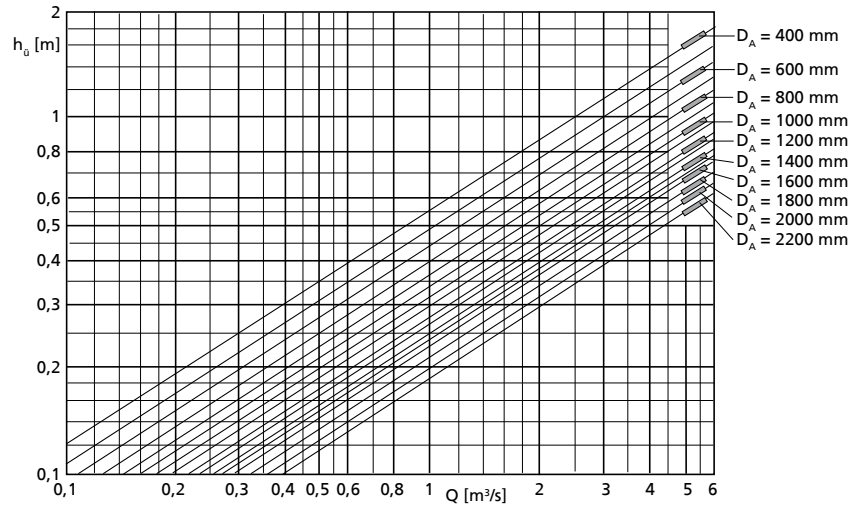

Loss diagram

Calculation formulas:

$$H = H_{geo} + \Delta H_v$$

$$\Delta H_v$$

- Overflow head h_u (see diagram)
- Loss in the riser (pipe friction)
- Outlet loss $v^2/2 g$ (v refers to D_A)

Overflow head h_u depends on Q and the discharge diameter D_A . The characteristic curve values only apply to unimpeded outlet in all directions; otherwise they are approximate values only.

Minimum water level diagram

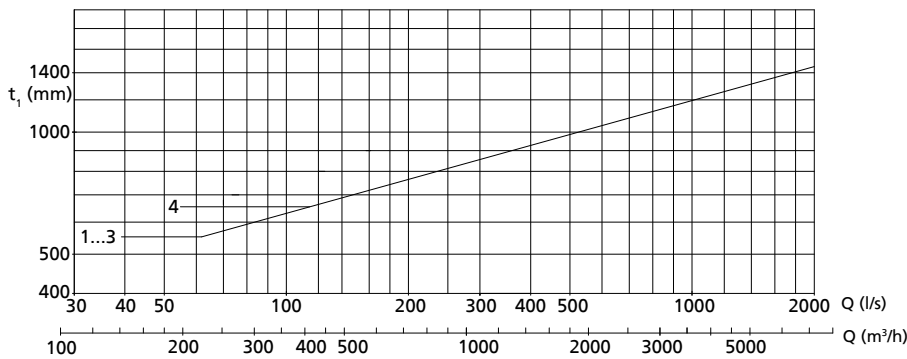

- 1 = Amacan K 700 / 800 - 330
- 2 = Amacan K 700 - 324 / 371
- 3 = Amacan K 800 - 370
- 4 = Amacan K 800 - 400 / 401

9.7.2 Installation type CU

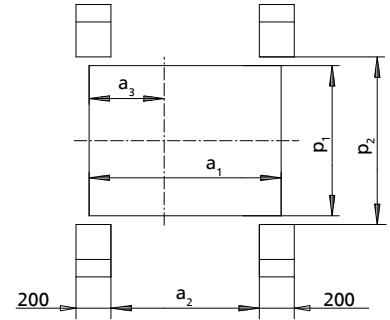
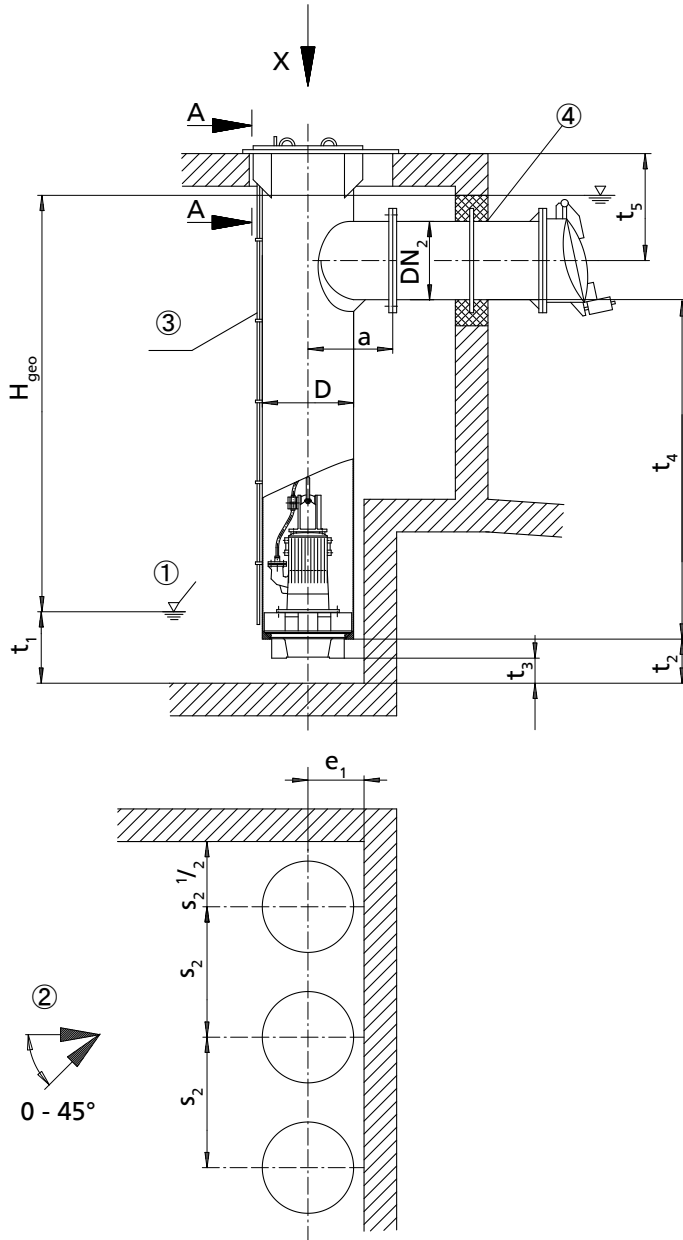

Foundation recesses⁹⁾

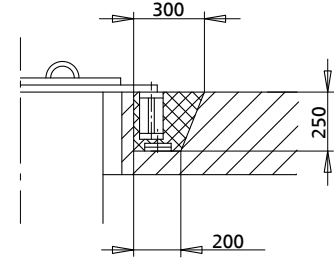

Section A - A:

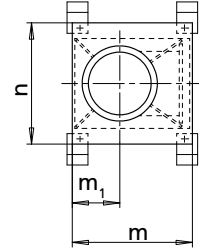

Detailed view X: Support plate of the discharge tube
Drawing: without pump

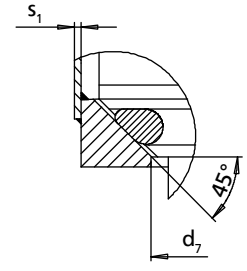

Detailed view Y: seat ring

- ①: Minimum water level (see diagram on the following page)
- ②: Approach flow
- ③: Vent line
- ④: Connect the discharge pipe to the discharge tube without transmitting any stresses or strains.

Table 33: Dimensions [mm]

Size	D	DN _{2 min}	DN _{2 max}	a	a ₁ ¹⁰⁾	a ₂ ¹⁰⁾	a ₃ ¹⁰⁾	d ₇	e ₁ ¹¹⁾	m ¹⁰⁾	m ₁ ¹⁰⁾	n ¹⁰⁾
700 - 324	711	300	600	650	1120	870	430	570	430	1170	455	1160
700 - 330	711	300	600	650	1120	870	430	570	430	1170	455	1160
700 - 371	711	300	600	650	1120	870	430	570	430	1170	455	1160
800 - 330	813	400	700	700	1220	970	480	570	480	1270	505	1260
800 - 370	813	400	700	700	1220	970	480	656	480	1270	505	1260

9) All dimensions for foundation recesses apply to discharge tube design without intermediate flange.
 10) Designed for DN 2 max.
 11) Always observe this dimension.

Size	D	DN _{2 min}	DN _{2 max}	a	a ₁ ¹⁰⁾	a ₂ ¹⁰⁾	a ₃ ¹⁰⁾	d ₇	e ₁ ¹¹⁾	m ¹⁰⁾	m ₁ ¹⁰⁾	n ¹⁰⁾
800 - 400	813	400	700	700	1220	970	480	656	480	1270	505	1260
800 - 401	813	400	700	700	1220	970	480	656	480	1270	505	1260

Table 34: Dimensions [mm]

Size	p ₁ ¹⁰⁾	p ₂ ¹⁰⁾	s _{1 min.}	s _{2 min.}	t ₂ ¹¹⁾	t ₃	t _{4 min.} ¹²⁾	t _{5 min.} ¹⁰⁾
700 - 324	860	960	8	1150	330	200	1250	720
700 - 330	860	960	8	1150	330	200	1250	720
700 - 371	860	960	8	1150	330	200	1250	720
800 - 330	960	1060	8	1150	330	200	1500	770
800 - 370	960	1060	8	1150	330	200	1450	770
800 - 400	960	1060	8	1400	410	250	1550	770
800 - 401	960	1060	8	1400	410	250	1550	770

Permissible tolerances:

- Tolerances in building construction to DIN 18202, Part 4, Group B
- Welded design: B/F to DIN EN ISO 13920
- Tolerances for conical seat (detailed view Y): ISO 2768-mH
- Discharge flanges to DIN EN 1092-1 PN6 / DIN EN 1092-2 PN6

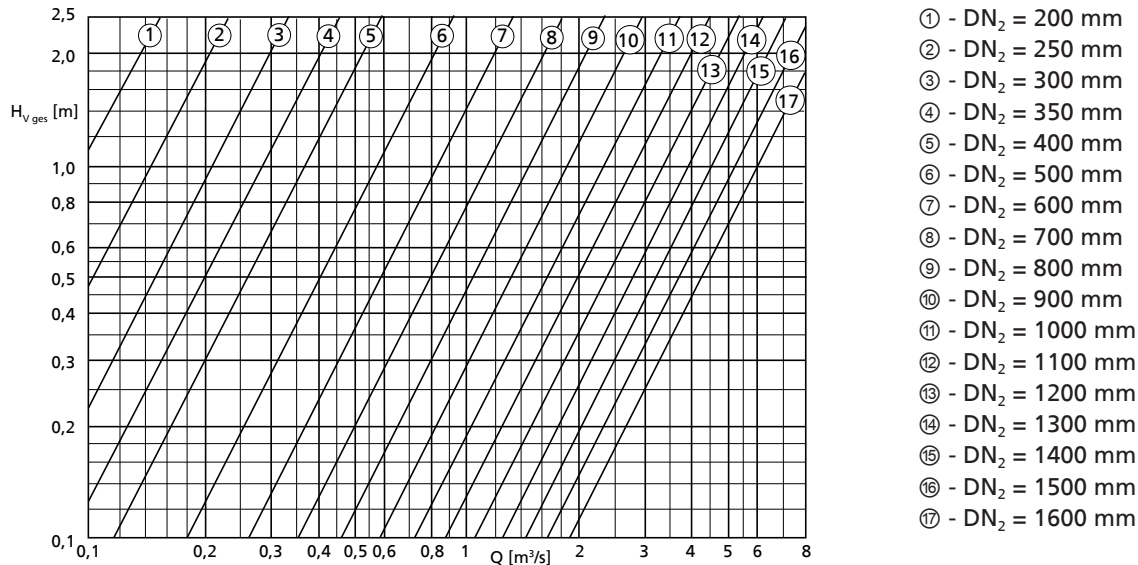
Loss diagram

Calculation formulas:

$$H = H_{\text{geo}} + \Delta H_v$$

$$\Delta H_v$$

- Loss in the riser (pipe friction)
- $H_{v \text{ ges.}}$ (see diagram)

 $H_{v \text{ ges.}}$ comprises:

- Elbow
- Discharge pipe length = 5 x DN₂
- Swing check valve
- Outlet losses $v^2/2g$

¹⁰⁾ Designed for DN 2 max.

¹¹⁾ Always observe this dimension.

¹²⁾ Value for maximum motor length

Minimum water level diagram

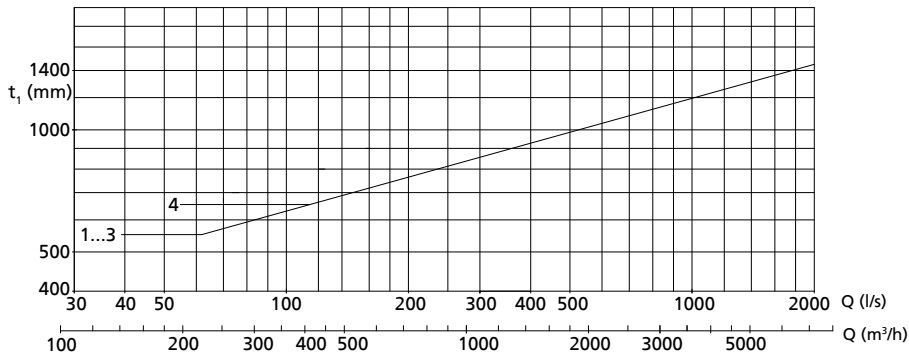

- 1 = Amacan K 700 / 800 - 330
- 2 = Amacan K 700 - 324 / 371
- 3 = Amacan K 800 - 370
- 4 = Amacan K 800 - 400 / 401

9.7.3 Installation type DU

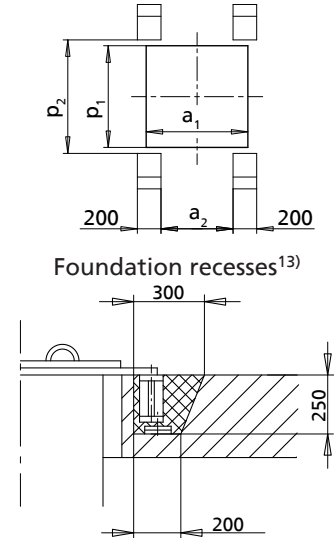
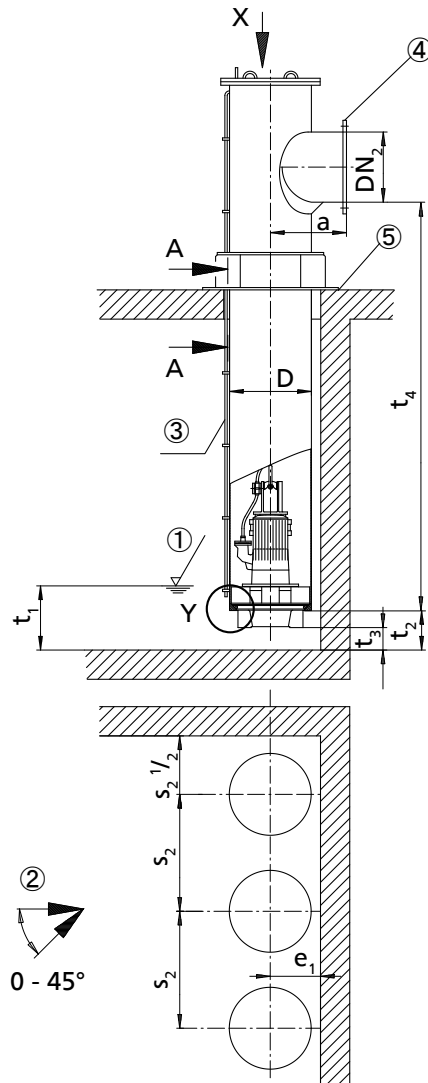

Section A - A:

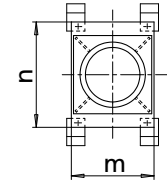

Detailed view X:
Support plate of the discharge tube
Drawing: without pump

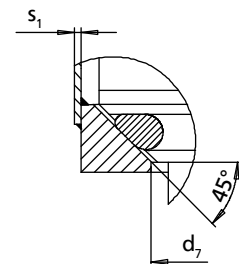

Detailed view Y:
seating ring

- ①: Minimum water level (see diagram on the following page)
- ②: Approach flow
- ③: Vent line
- ④: Connect the discharge pipe to the discharge tube without transmitting any stresses or strains.
- ⑤: Not pressure-proof

Table 35: Dimensions [mm]

Size	D	DN _{2 min}	DN _{2 max}	a	a ₁	a ₂	d ₇	e ₁ ¹⁴⁾	m	n
700 - 324	711	300	600	650	860	610	570	430	930	1160
700 - 330	711	300	600	650	860	610	570	430	930	1160
700 - 371	711	300	600	650	860	610	570	430	930	1160
800 - 330	813	400	700	700	960	710	570	480	1030	1260
800 - 370	813	400	700	700	960	710	656	480	1030	1260
800 - 400	813	400	700	700	960	710	656	480	1030	1260
800 - 401	813	400	700	700	960	710	656	480	1030	1260

¹³⁾ All dimensions for foundation recesses apply to discharge tube design without intermediate flange.

¹⁴⁾ Always observe this dimension.

Table 36: Dimensions [mm]

Size	P ₁	P ₂	S _{1 min}	S _{2 min}	t ₂ ¹⁴⁾	t ₃	t _{4 min.} ¹⁵⁾
700 - 324	860	960	8	1150	330	200	1250
700 - 330	860	960	8	1150	330	200	1250
700 - 371	860	960	8	1150	330	200	1250
800 - 330	960	1060	8	1150	330	200	1500
800 - 370	960	1060	8	1150	330	200	1450
800 - 400	960	1060	8	1400	410	250	1550
800 - 401	960	1060	8	1400	410	250	1550

Permissible tolerances:

- Tolerances in building construction to DIN 18202, Part 4, Group B
- Welded design: B/F to DIN EN ISO 13920
- Tolerances for conical seat (detailed view Y): ISO 2768-mH
- Discharge flanges to DIN EN 1092-1 PN6 / DIN EN 1092-2 PN6

Loss diagram

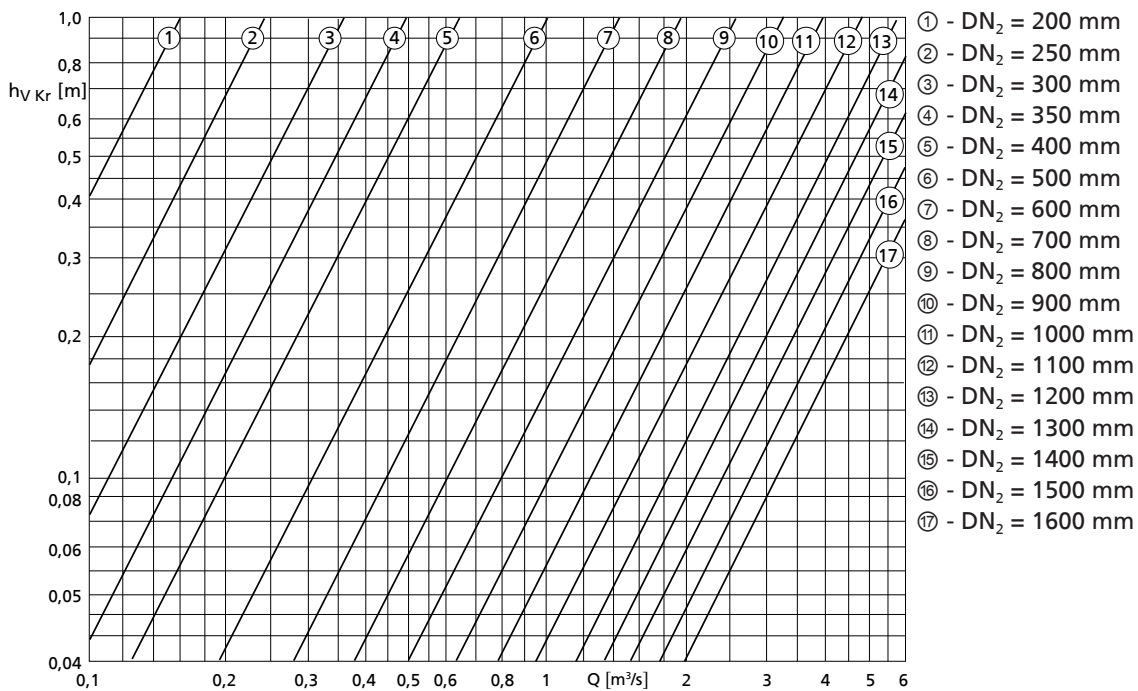

Calculation formulas:

$$H = H_{geo} + \Delta H_v$$

$$\Delta H_v$$

- Loss in the elbow $h_{v Kr}$ (see diagram)
- Loss in the riser (pipe friction)
- $H_{V System}$ (valves, etc.)

$H_{V System}$ must be determined for the specific system.

¹⁵⁾ Value for maximum motor length

Minimum water level diagram

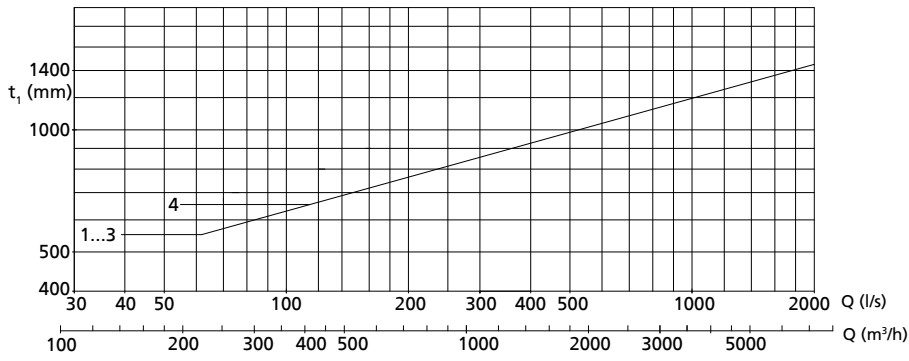

- 1 = Amacan K 700 / 800 - 330
- 2 = Amacan K 700 - 324 / 371
- 3 = Amacan K 800 - 370
- 4 = Amacan K 800 - 400 / 401

10 EU Declaration of Conformity

Manufacturer: **KSB Aktiengesellschaft**
Johann-Klein-Straße 9
67227 Frankenthal (Germany)

The manufacturer herewith declares that the product:

Amacan K, Amacan P, Amacan S

KSB order number:

- is in conformity with the provisions of the following Directives as amended from time to time:
 - Pump (set): Machinery Directive 2006/42/EC

The manufacturer also declares that

- the following harmonised international standards have been applied:
 - ISO 12100
 - EN 809
 - EN 60034-1, EN 60034-5/A1

Person authorised to compile the technical file:

Name
Function
Address (company)
Address (Street, No.)
Address (post or ZIP code, city) (country)

The EU Declaration of Conformity was issued in/on:

Place, date

.....¹⁶⁾.....

Name
Function
Company
Address

¹⁶⁾ A signed, legally binding EU Declaration of Conformity is supplied with the product.

11 Certificate of Decontamination

Type:
 Order number/
 Order item number¹⁷⁾:

Delivery date:

Field of application:

Fluid handled¹⁷⁾:

Please tick where applicable¹⁷⁾:



Radioactive



Explosive



Corrosive



Toxic



Harmful



Bio-hazardous



Highly flammable



Safe

Reason for return¹⁷⁾:

Comments:

The product/accessories have been carefully drained, cleaned and decontaminated inside and outside prior to dispatch/ placing at your disposal.

We herewith declare that this product is free from hazardous chemicals, biological and radioactive substances.

For mag-drive pumps, the inner rotor unit (impeller, casing cover, bearing ring carrier, plain bearing, inner rotor) has been removed from the pump and cleaned. In cases of containment shroud leakage, the outer rotor, bearing bracket lantern, leakage barrier and bearing bracket or intermediate piece have also been cleaned.

For canned motor pumps, the rotor and plain bearing have been removed from the pump for cleaning. In cases of leakage at the stator can, the stator space has been examined for fluid leakage; if fluid handled has penetrated the stator space, it has been removed.

- No special safety precautions are required for further handling.
- The following safety precautions are required for flushing fluids, fluid residues and disposal:

.....

We confirm that the above data and information are correct and complete and that dispatch is effected in accordance with the relevant legal provisions.

.....
 Place, date and signature

.....
 Address

.....
 Company stamp

¹⁷⁾ Required fields

Index

A

Abrasive fluids 41
Applications 7

B

Bearing temperature monitoring 35
Bearings 17

C

Certificate of decontamination 86
Commissioning 38

D

Design 17
Designation 16
Dismantling 52
Disposal 15
Drive 17

E

Electrical connection 36
Electromagnetic compatibility 32
Event of damage
 Ordering spare parts 60
Explosion protection 9, 20, 22, 23, 32, 33, 34, 36, 37,
39, 40, 43, 44, 55, 56

F

Faults
 Causes and remedies 61
Fluid handled
 Density 40

I

Impeller type 17
Installation 20
Installation at site 20
Intended use 7
Interference immunity 33

L

Leakage monitoring 35

Level control system 32
Lubricant 48
 Quantity 48

M

Misuse 8

O

Operation on a frequency inverter 32, 40
Order number 6
Other applicable documents 6
Overload protection 31

P

Partly completed machinery 6
Preservation 14
Product description 16

R

Reassembly 52
Return to supplier 15
Returning to service 42

S

Safety 7
Safety awareness 8
Scope of supply 19
Sensors 33
Shaft seal 17
Shutdown 42
Spare part
 Ordering spare parts 60
Spare parts stock 60
Start-up 39
Storage 14, 42
Supply voltage 39

T

Temperature monitoring 34
Tightening torques 59

W

Wiring diagrams 70



KSB Aktiengesellschaft

67225 Frankenthal • Johann-Klein-Str. 9 • 67227 Frankenthal (Germany)

Tel. +49 6233 86-0 • Fax +49 6233 86-3401

www.ksb.com