

4Spider – for KSB's submersible motors

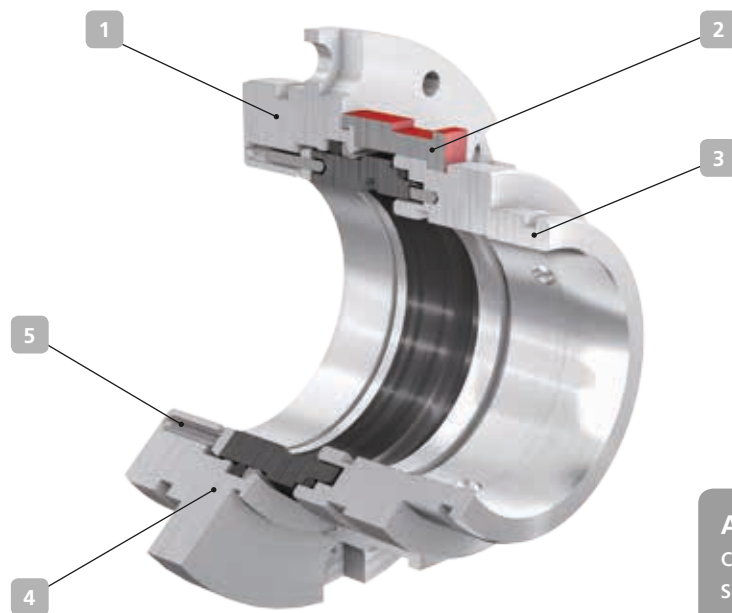

Applications:
contaminated water,
seawater

1 Compact

Single, balanced cartridge seal, bi-directional, tailored to the seal installation space.

2 Service-friendly

Easy to install, no adjusting dimension required Easy installation and removal also under difficult operating conditions.

3 Versatile

For all operating conditions the submersible motor is approved for.

4 Tailored

The permissible spring travel accommodates for the technical requirements of the motor shaft and thrust bearing. Depending on the size, the sleeve of the mechanical seal also houses the connection between coupling and pump, thus keeping the shaft dry.

5 Dependable

Stationary design; the multi-spring arrangement provides uniform surface pressure across the seal faces, thus ensuring a long service life.

Technical description

Design	Single cartridge seal
Type	Stationary, balanced
Springs	Multi-spring arrangement
Direction of rotation	Bi-directional

Materials

Primary ring	SiC (Q1)
Mating ring	SiC (Q1)
Elastomers	FKM (V)
Springs	2.4610 (M)
Other Components	1.4501 (G4), 1.4462 (G1)

Other material combinations on request

Technical data

Operating pressure	Up to 20 bar, dynamic Up to 30 bar, static
Temperature	0 °C to 80 °C
Seal size	056 / 066 / 076 / 100
Business type	Standard